



Clinical and Technical Manual

*V*Home, Software Versions 5.02 to 5.03*



Copyright: © 2024, Ventec Life Systems
22002 26th Ave SE
Bothell, WA 98021 USA

Part Number: LBL-00354-000, Rev C

CAUTION: Federal law restricts this device to sale and use by or on the order of a physician.

Table of Contents

Introduction 10

- Therapy Overview ----- 10
- Leak+ Performance ----- 11
- Ventilation ----- 11
- Portability ----- 11
- Indications for Use ----- 12
- V*Home Training ----- 12
- Suggested Environments of Use ----- 13
- Home Environments ----- 13
- Hospital Environments ----- 13
- Institutional Environments ----- 13
- Transport Environments ----- 13
- Getting Started ----- 14
- Package Contents ----- 14
- Contraindications ----- 14
- System Overview ----- 15

Setup 16

- V*Home Placement ----- 17
- Power Setup ----- 18
- The Power Supply ----- 19
- The Optional 24 Volt Wheelchair Power Cable ----- 20
- The Removable, Rechargeable Batteries ----- 20
- Ventec One-Circuit Setup ----- 21
- Using a Trach, ET Tube, or Non-Vented Mask ----- 22
- Using a Vented Mask ----- 22
- Using a High Flow Nasal Cannula ----- 22
- Connecting a Passive or Valveless Ventec One-Circuit ----- 23
- Ventec One-Circuit Component Connection Order ----- 24
- Connecting an External Bacterial Filter ----- 25

- Connecting a Passive Ventec One-Circuit with HME ······ -25
- Connecting a Humidifier and Heated Wire Ventec One-Circuit ······ -26
- Connecting Ventec One-Circuit Components ······ -27
 - Connecting an HME (Heat-Moisture Exchanger) ······ -27
 - Connecting an External Nebulizer Cup to the Patient Circuit ······ -28
- Setting up Ventilation Therapy with a Speaking Valve ······ -29
- Mouthpiece Patient Circuit Setup ······ -30
- Oxygen Therapy Setup ······ -31
 - Setting Up External Oxygen Sources ······ -31
 - Connecting External Low-Pressure Oxygen ······ -32
- Connecting a Nurse Call System or Remote Alarm ······ -33
- Running the Pre-Use Test ······ -34
- Connecting a React DataLink™ ······ -35

Breath Types and Therapy Modes 36

- Breath Types ······ -36
 - Pressure Breaths ······ -37
 - Volume Breaths ······ -38
 - Spontaneous Breaths ······ -38
- V*Home Ventilation Modes ······ -39
 - Bi-Level Mode ······ -39
 - Assist/Control-Pressure with a Passive, or Valveless Ventec One-Circuit ······ -40
 - Assist/Control-Pressure with a Mouthpiece Patient Circuit ······ -40
 - SIMV-Pressure Mode ······ -41
 - CPAP Function ······ -41
 - High Flow Therapy ······ -41
 - Assist/Control-Volume Mode ······ -42
 - Assist/Control-Volume with a Passive, or Valveless Ventec One-Circuit ······ -42
 - Assist/Control-Volume with a Mouthpiece Patient Circuit ······ -42
 - SIMV-Volume Mode ······ -43
 - Volume Targeted Ventilation Overview ······ -44
 - Vol. Targeted-PS Mode ······ -45
 - Vol. Targeted-PS with a Passive, or Valveless Ventec One-Circuit ······ -45
 - Vol. Targeted-PS with a Mouthpiece Patient Circuit ······ -45
 - Vol. Targeted-PC Mode ······ -46
 - Vol. Targeted-PC with a Passive or Valveless Ventec One-Circuit ······ -46
 - Assist/Control-Pressure with a Mouthpiece Patient Circuit ······ -46
 - Vol. Targeted-SIMV Mode ······ -47
 - Comparable Volume Ventilation Modes ······ -48
 - Comparable Pressure Ventilation Modes (Including Volume-Targeted Ventilation) ······ -49
 - Comparable Non-Invasive Ventilation Modes ······ -50

The Touchscreen 51

Locking the Touchscreen - - - - -51

Quick View - - - - -51

The Status Bar - - - - -52

The Home Screen - - - - -53

 Night Mode and Day Mode - - - - -53

The Therapy Screen - - - - -54

The Monitors Screen - - - - -54

 The Customization Button - - - - -55

 The Waveforms Button - - - - -55

The Menu Screen - - - - -56

 The Pre-Use Test Button - - - - -56

 The Settings & Alarms Button - - - - -57

 The Device Settings Button - - - - -57

 The Logs Button - - - - -57

 The Clinician Access Button - - - - -57

 The Enable Prescribed Therapies Button - - - - -58

 The Permissions Button - - - - -58

 The My VOCSN Button - - - - -58

Controls and Settings 59

Ventilation Therapy Controls - - - - -60

 Changing Ventilation Therapy Settings - - - - -60

 Available Ventilation Therapy Settings - - - - -61

 Control Limiting - - - - -67

 Controls Available in Each Ventilation Mode - - - - -68

 Setting V*Home Controls for Mouthpiece Ventilation - - - - -71

 Setting V*Home Controls for High Flow Therapy - - - - -71

Enabling and Disabling Prescribed Therapies - - - - -72

Oxygen Controls - - - - -73

 Changing Oxygen Settings - - - - -73

 Available Oxygen Settings - - - - -73

Changing Nebulizer Compensation Settings - - - - -75

Clinician Access Mode - - - - -76

 Entering the Clinician Access Passcode - - - - -76

Configuring Permissions - - - - -77

Device Settings - - - - -78

 Changing Device Settings - - - - -78

 Available Device Settings - - - - -79

Alarms 80

Alarm Silence Button - - - - -81

Changing Alarm Settings - - - - -81

Alarm Conditions and Settings - - - - -82

The Alarm Log	-91
The Mark Event Button	-91
The Event Log	-92
Clearing an Alarm	-93
Remote Alarms and Nurse Call Systems (Optional)	-93

Monitors 94

Ventilation Monitors	-95
Waveform Monitors	-97
Monitor Screen Customization	-98
Oxygen Therapy Monitors	-99
FiO2 Monitor	-99
Nebulizer Compensation Monitor	-100
System Monitors	-101

Multi-View 102

Exporting Multi-View Data to a USB Drive	-103
Generating Multi-View Reports	-104
Reading Multi-View Reports	-105
Report Information	-105
Trend Summary	-106
Compliance Calendar	-106
Therapy Use	-107
Settings Overview	-107
Monitor Details	-108
Logs	-109

Checkout Procedure 110

Visual Inspections	-110
Inop Alarm Test	-110
Power Testing Procedures	-111
Ventilation Testing Procedures	-112
Ventilation Tests	-113
Ventilation Alarm Verification	-114
Remote Alarm Test (Optional)	-114
Decannulation Alarm Verification	-115
Patient Circuit Disconnect Alarm Verification	-115
Configure and Verify Control and Alarm Settings	-115
Checkout Worksheet	-116

Operating Instructions 117

Powering On V*Home - - - - - 118

Starting V*Home Therapies - - - - - 119

 Starting Ventilation Therapy - - - - - 120

 Changing Between Configured Ventilation Presets - - - - - 121

 Starting Oxygen Therapy - - - - - 122

 Starting Nebulizer Compensation - - - - - 123

Responding to Alarms - - - - - 124

Powering Off V*Home - - - - - 124

Cleaning and Maintenance 125

Cleaning V*Home - - - - - 125

 Cleaning V*Home Exterior - - - - - 126

 Cleaning the Air and Fan Filters - - - - - 127

Replacing Components - - - - - 128

 Replacing the Power Supply - - - - - 128

 Replacing the Ventec One-Circuit - - - - - 128

 Replacing Ventec One-Circuit Components - - - - - 129

 Replacing the External Bacterial Filter - - - - - 129

 Replacing the Internal Bacterial Filter - - - - - 130

Recommended Maintenance Schedule - - - - - 131

Battery Care, Maintenance, and Replacement - - - - - 132

 Battery Storage Mode - - - - - 133

Software Updates - - - - - 134

 Locating the V*Home Software Version - - - - - 135

Environmental Considerations - - - - - 135

Shipping Considerations - - - - - 135

Glossary 136

Glossary of Symbols - - - - - 136

Glossary of Indicators - - - - - 139

Glossary of Terms - - - - - 141

Troubleshooting 143

Troubleshooting Alarms - - - - - 143

Device Troubleshooting - - - - - 148

Ventilation and Troubleshooting - - - - - 149

Oxygen Troubleshooting - - - - - 150

Multi-View Troubleshooting - - - - - 150

Patient Circuit Troubleshooting - - - - - 150

Recalibrating Batteries - - - - - 151

Technical Specifications	152
Physical	152
Environmental	153
Inputs and Outputs	153
External Power Requirements	153
Removable, Rechargeable Batteries	154
Internal Rechargeable Battery	154
Expected Service Life and Intervals	155
Audible Volume	155
FiO2 Monitor	155
Control Accuracy	156
Monitor Resolution and Accuracy	158
Classifications	160
Standards Applied	160
Ventec One-Circuit Compliance	161
Pressure During Inop	161
Biocompatibility	161
Accessories	162
Available from Ventec Life Systems	162
Available from Other Manufacturers	166
EMC Information	167
Electromagnetic Emissions	168
Electromagnetic Immunity	169
Recommended Separation Distance Between Portable and Mobile RF Communications Equipment and V*Home	171
Technical Description	172
Theory of Operation	172
Ventilation Therapy	172
Leak Compensation	173
Leak Compensation with a Passive or Valveless Ventec One-Circuit	173
Leak Compensation with a Mouthpiece Circuit	173
Nebulization	174
External Nebulizer Compensation	174
V*Home Measurements	175
Airway Pressure Measurements	175
Flow Measurements	175
Volume Measurements	175
FiO2 Measurements	175
Alarm Detection Criteria	176

System Fault Detection Criteria and Recommended Action -----177

Low-Pressure Oxygen Blending -----178

 Input Flow 100% Oxygen, Flow Trigger Set to 1-3 -----179

 Input Flow 100% Oxygen, Flow Trigger Set to 9 -----179

 Input Flow 93% Oxygen, Flow Trigger Set to 1-3 -----180

 Input Flow 93% Oxygen, Flow Trigger Set to 9 -----180

 Input Flow 100% Oxygen, High Flow Therapy -----181

 Input Flow 93% Oxygen, High Flow Therapy -----181

Introduction

Therapy Overview

Using the Ventec One-Circuit®, clinicians, home caregivers, and patients can use V*Home to ventilate the patient.

NOTE: This manual describes the features included with software version 5.02 to 5.03 for the V*Home Configuration only. For instructions for use of other model VOCSN configurations and software versions, see the links to Clinical and Technical Manuals available at VentecLife.com

Leak+ Performance

The Leak+ feature allows V*Home to deliver High Flow ventilation, as well as provide compensation for leaks up to 175 L/min at 20 cmH₂O. The improved Leak Compensation may be particularly useful during non-invasive ventilation. Leak+ is available on devices with compatible hardware running software version 4.06R and newer.

To see if your V*Home is capable of Leak+ performance, install the latest software and check for the “V” icon with a white background in the status bar. The availability of this feature can also be found on the [My VOCSN](#) screen next to “Leak+.”



For more information about leak compensation, see *“Leak Compensation” on page 173.*

WARNING: Delivered and monitored ventilation therapy may be affected by large leaks around the patient interface.

Ventilation

V*Home provides invasive or non-invasive ventilation. Using one of six ventilation modes, and a passive, valveless, or mouthpiece Ventec One-Circuit, V*Home delivers configurable pressure, volume, and/or spontaneous breaths.

The configurable Flow Trigger control, in combination with the powerful integrated Leak Compensation feature, allows V*Home to perform well for both invasive and non-invasive applications, even with significant leaks in the patient circuit. V*Home devices with the Leak+ feature can compensate for leaks up to 175 L/min at 20 cmH₂O. Ventilation controls such as Rise Time and Pressure Control Flow Termination can be adjusted to improve patient comfort.

The Ventilation therapy Presets feature allows clinicians to set up, label, and store up to three unique Ventilation therapy configurations. Using the touchscreen, clinicians, home caregivers, and patients can switch between these three pre-configured therapies as needed. For example, some patients may benefit from one ventilation Preset while awake, another Preset while active, and a third Preset during sleep.

The Permissions feature allows clinicians to lock V*Home control settings. V*Home controls can be set to User and Clinician, or Clinician Only. Controls set to Clinician Only cannot be modified until the Clinician Access Passcode is entered. Controls set to User and Clinician will remain adjustable at all times.

Oxygen can be flowed into the Ventec One-Circuit through the low-pressure oxygen port.

Portability

V*Home is designed to support the transport of mechanically ventilated patients. V*Home includes two removable, rechargeable batteries and an internal rechargeable battery, used to power the device when no external source of continuous power is available.

Using the power supply, V*Home can be connected to a wall outlet or other AC power source. Ventec Life Systems also offers an optional 24 Volt Wheelchair Power Cable, which can be used to power V*Home from wheelchair outlets. V*Home batteries charge whenever an external power source is applied.

Indications for Use

V*Home Unified Respiratory System is intended to provide continuous or intermittent ventilatory support for the care of individuals who require mechanical ventilation. It may be used in invasive and non-invasive applications. V*Home is intended for pediatric through adult patients weighing at least 5 kg. It is intended for use in home, hospital, institutional, and transport settings, including portable applications.

V*Home Training

The V*Home clinician or caregiver must be capable of responding to alarm conditions, and trained to use V*Home. A list of available V*Home training options is available at VentecLife.com.

CAUTION: Clinicians responsible for configuring and operating V*Home must be trained to use it and should review this manual in its entirety before using V*Home to administer therapy. Home caregivers must also receive training, and must review the Home Caregiver and Patient Guide (available at VentecLife.com) prior to setting up or operating V*Home.

Suggested Environments of Use

V*Home is suitable for use in the following environments:

Home Environments

- Home care
- Home-based transport

Hospital Environments

- Emergency departments
- Step-down units
- Military hospitals

WARNING: Do not use V*Home within magnetic resonance (MR) environments. Using V*Home within MR environments may affect V*Home or MR device performance, damage the devices, or harm individuals.

Institutional Environments

- Long-term acute care
- Skilled nursing facilities
- Long-term care/nursing homes

Transport Environments

- Intra-hospital transport
- Inter-hospital transport
- Emergency medical services
- Military transport

Getting Started

Package Contents

V*Home includes the following items:

- One V*Home
- Two removable, rechargeable batteries
- One power supply
- One Ventec One-Circuit
- Bacterial filters
- One Quick Start Guide

NOTE: Contact Ventec Life Systems at 1-844-MY-VOCSN for assistance with setup, maintenance, or to report unexpected device operation.

See *"Accessories"* on page 162 for a list of V*Home components and accessories available from Ventec Life Systems.

Contraindications

Consult the patient's healthcare professional before using a non-invasive interface with V*Home if the patient experiences any of the following medical conditions:

- Inability to maintain a patent airway
- Risk of aspirating gastric contents
- Epistaxis that causes pulmonary aspiration of blood
- Acute sinusitis or otitis media
- Hypotension

System Overview

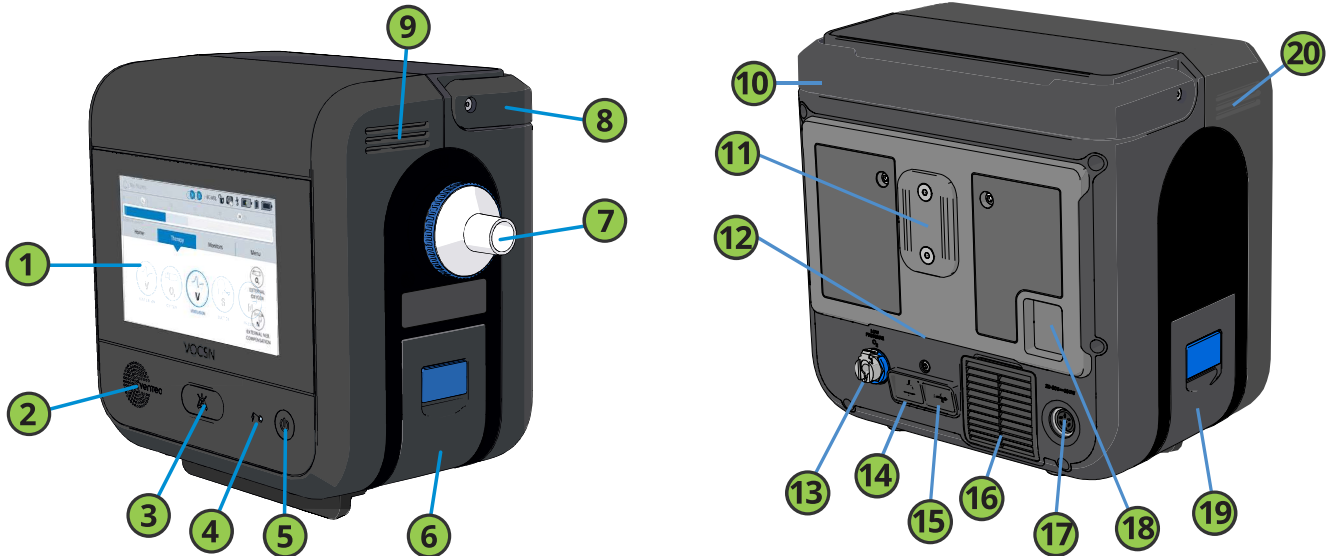

Description		Description	
1	Touchscreen	10	Handle (back view)
2	Speaker	11	T-Slot mount
3	Alarm Silence button	12	Cooling air outlet
4	External Power / Charge Status indicator light	13	Low-pressure O2 Inlet
5	On/Off button and indicator light	14	Remote alarm port
6	Removable, rechargeable battery (right side)	15	USB port for use by trained personnel only. See <i>“Exporting Multi-View Data to a USB Drive”</i> on page 103 for instructions.
7	External bacterial filter and Ventec One-Circuit connection port	16	Cooling air intake and filter
8	Handle (side view)	17	Power connection port
9	Cooling air outlet	18	Patient air inlet and filter
		19	Removable, rechargeable battery (left side)
		20	Cooling air outlets

Setup

This chapter includes instructions for placing and setting up V*Home, including instructions for connecting Ventec One-Circuits, and additional Ventec One-Circuit components. V*Home was designed for use with Ventec One-Circuits from Ventec Life Systems. Do not use third-party patient circuits with V*Home.

WARNING: Put V*Home into service in accordance with the information provided in this Clinical and Technical Manual. V*Home operation may be impaired or become unsafe by failure to follow setup and operating instructions, the connection of unauthorized accessories, or the unauthorized modification of V*Home. All modifications made, and accessories used with V*Home, must meet the requirements of IEC 60601-1. The organization responsible for device setup must ensure the compatibility of V*Home and all parts and accessories used to provide therapy to the patient prior to use.

WARNING: V*Home should be set up, configured, and used by trained clinicians and caregivers under the direction of a physician. Patients and caregivers should be instructed not to modify the V*Home setup or configuration without direction and/or supervision from a clinician.

WARNING: Do not use lubricants on V*Home or on any part of the Ventec One-Circuit. Lubricating fittings, connections, tubing, or other accessories may result in fire and burns to the patient or caregiver.

WARNING: Use only spare parts recommended by Ventec Life Systems. Using spare parts not recommended by the V*Home manufacturer may result in fire and burns to the patient or caregiver.

WARNING: Only use carrying cases approved by Ventec Life Systems. Use of unauthorized carrying cases may result in damage to V*Home, impaired device performance, and risk to the patient.

NOTE: The V*Home Ethernet and USB ports are intended for use by trained personnel only. The remote alarm port and power connection port can be used with third-party equipment. However, it is the responsibility of the person connecting the third-party equipment to ensure the system complies with clause 16 of IEC 60601-1, 3rd ed., as well as any local laws.

NOTE: When using V*Home to provide non-invasive ventilation, Ventec Life Systems recommends use of CO₂ monitoring equipment compliant with ISO 80601-2-55. To connect and use CO₂ monitoring with V*Home, follow all instructions from the equipment manufacturer.

V*Home Placement

Place V*Home in a well-ventilated area, ensuring air flows freely around its inlets and vents.

WARNING: Incorrect placement of V*Home may affect device performance. Do not cover V*Home, place it in an area in which the vents may become obstructed (such as on its back or on top of compliant bedding), or use it in hazardous environments (such as atmospheres containing pollutants).

NOTE: V*Home emits heat and gas, including nitrogen, during normal operation. Use V*Home in a well-ventilated area.

When used in a home environment, V*Home should be kept away from concentrations of lint, dust, pet dander, and pests. Small particles and/or pests can clog V*Home filters over time and become lodged inside V*Home. Clean the air and fan filters regularly to prevent clogging, and move V*Home to a new location if large volumes of particulate are pulled into the filters. Place V*Home somewhere it will not be easily accessible by children or pets, such as on a roll stand.

WARNING: Keep V*Home out of reach of children to avoid the risk of strangulation by cords and tubes, as well as the risk of inhalation or swallowing of small parts. V*Home includes a hook-and-loop strap to wrap power adapter cabling when not in use.

Over time, direct sunlight may compromise the integrity of V*Home plastic housing or the Ventec One-Circuit. Place V*Home in a location that is not exposed to extended periods of direct sunlight.

WARNING: Use of V*Home outside its recommended range of temperature, altitude, and/or relative humidity may adversely affect the ventilation flow rate and oxygen concentration from V*Home, and may result in patient harm. See *“Environmental” on page 153* for details.

WARNING: Do not use V*Home in contaminated, hazardous, or explosive environments. Use of V*Home can be hazardous in these conditions.

WARNING: To protect against EMI (electromagnetic interference) affecting device performance:

- Do not use V*Home within electromagnetic fields exceeding the limits specified in *“EMC Information” on page 167*. Common sources of electromagnetic fields include security systems, wireless communications equipment, appliances, and medical imaging systems.
- Do not stack V*Home with other electrical devices during use.
- Do not connect V*Home to unauthorized cables or accessories. Use of cables or other accessories not approved for use with V*Home may result in increased electromagnetic emissions or decrease its immunity from other sources of EMI.

WARNING: Accidental button presses could result in inadvertent alteration of the V*Home configuration or its operation. To reduce the possibility of accidental button presses, do not place in areas that might result in inadvertent touching of the V*Home touchscreen or its buttons. Use the touchscreen lock feature during cleaning or transport.

Power Setup

V*Home operates using external power (such as a wall outlet), or V*Home batteries. Ventec Life Systems recommends connecting V*Home to a continuous external power source whenever possible. During transport, Ventec Life Systems recommends the use of external power or the removable batteries. Use the internal (non-removable) battery in case of power failure or power transition only.

NOTE: Use only the power supply approved by Ventec Life Systems to connect V*Home to external sources of power. Ensure the external source of power is rated for use with V*Home. See *“External Power Requirements” on page 153* for more information.

The V*Home batteries will begin charging whenever an external power source is applied. All V*Home features and functions operate normally during battery charging. The charge status indicator light on the front of V*Home will illuminate orange when the batteries are charging, and illuminate green when the batteries are fully charged. In the status bar, a lightning bolt will appear on the battery indicator of the charging battery.

NOTE: When V*Home is disconnected from external power and transitions to running on battery power, or switches from running on removable battery to internal battery power, the medium-priority Battery Use alarm will activate.

WARNING: Check the batteries and external power supply regularly to ensure functionality. V*Home power failure may interrupt ventilation therapy and result in patient harm or death. See *“Power Testing Procedures” on page 111* for instructions.

If the internal battery depletes fully, V*Home Date and Time settings will reset to their default values. To ensure the Alarm and Event logs record information accurately, verify the V*Home Date and Time settings before use, and set them to the correct values if necessary.

The Power Supply

The power supply included with V*Home is part of the ventilation system, and powers the device from AC wall outlets.

Before and during use, periodically inspect the power supply for damage or frays, and to ensure the power supply cords are firmly connected. Do not use damaged power supplies. Replace the power supply if necessary.

The power supply includes a wire retention clip. To ensure the cabling remains seated in the adapter, rotate the retention clip so that it secures the cable to the adapter.

The power supply also comes with a hook-and-loop strap to manage excess cabling. Coil extra cabling between the outlet and VOCSN, and then wrap the strap around the cabling to secure it.

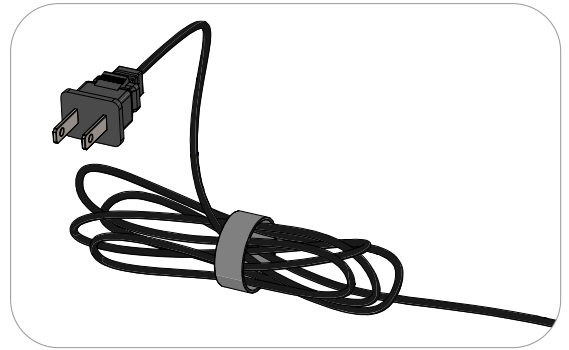
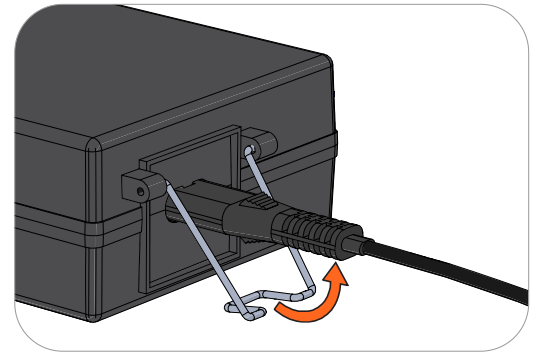

NOTE: Position V*Home so that it can be easily disconnected from the AC supply mains. To disconnect V*Home from the AC supply mains, unplug the power supply from the outlet.

NOTE: Do not use portable (e.g., external 115-volt AC) power supplies to power V*Home, unless the power supply voltage variations are known to be within V*Home operating limits. See *"External Power Requirements"* on page 153.

To connect V*Home to a continuous source of external power using the AC Adapter:

- 1** Plug the power supply into the power connection port on the back of V*Home, and screw the connector clockwise to secure it in place.
- 2** Plug the power supply into a power socket, such as a wall outlet, and verify the external power indicator (🔌) appears on the touchscreen.

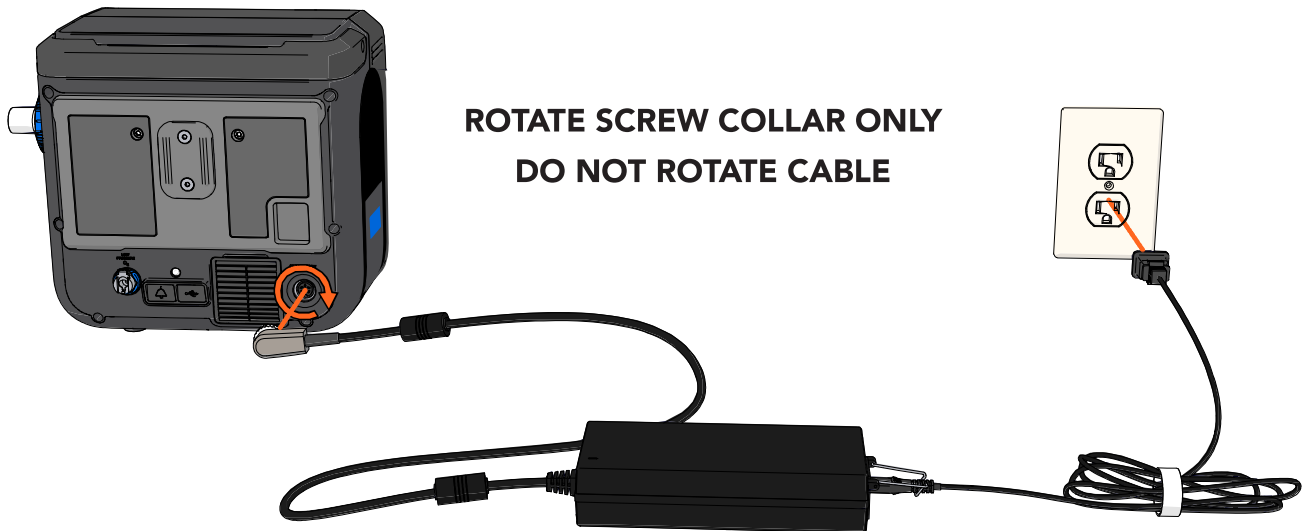

The Optional 24 Volt Wheelchair Power Cable

An optional 24 Volt Wheelchair Power Cable is available from Ventec Life Systems. The 24 Volt Wheelchair Power Cable can be used to connect V*Home to external sources of DC power, such as wheelchair power outlets.

PRECAUTION: When connected to an external battery (such as a wheelchair battery), V*Home pulls power from it to run and charge its own batteries. This may affect battery life and/or wheelchair performance (for instance, driving uphill).

When connected to wheelchair power for long periods of time, it may be beneficial to implement a supplemental energy use strategy. For example, traveling with an AC power supply and/or additional, charged V*Home removable batteries.

The 24 Volt Wheelchair Power Cable comes with a hook-and-loop strap to manage excess cabling. Coil extra cabling between the outlet and V*Home, and then wrap the strap around the cabling to secure it.

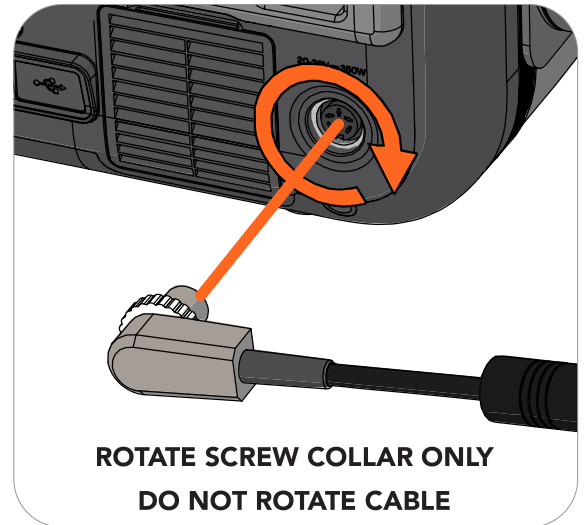

NOTE: Before connecting the 24 Volt Wheelchair Power Cable to a power source, you must verify the voltage and current emitted from the DC power source are within the range of V*Home operating limits, and that the power source has the correct connection type. See *"External Power Requirements"* on page 153.

The Removable, Rechargeable Batteries

V*Home includes two removable, rechargeable batteries. These batteries may be removed and reinstalled during V*Home use.

To remove a battery:

- 1** Lift the blue battery tab.
- 2** Use the tab to pull the battery out of the well gently.

To install a battery:

- 1** Lift the blue battery tab.
- 2** Gently press the battery into the well. Place the base of the battery into the well first, and then press the top of the battery toward V*Home and into the well.
- 3** Press the battery tab down so that it is flat against the battery.

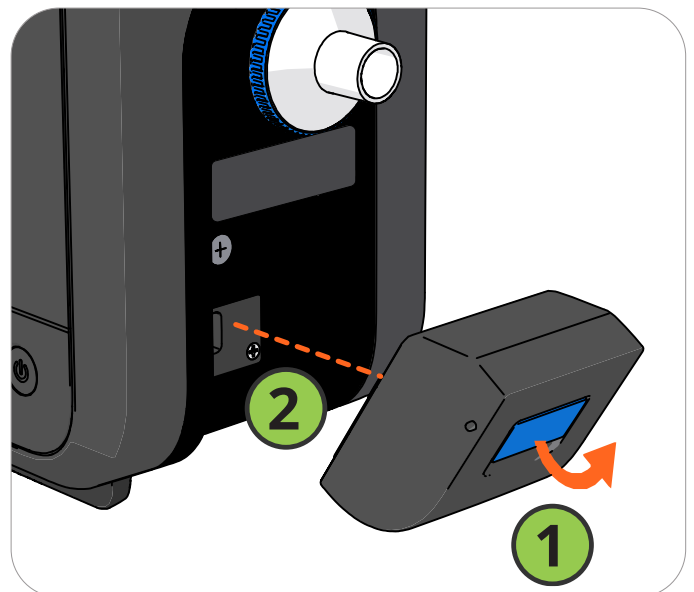

Ventec One-Circuit Setup

V*Home was designed for use with Passive, Valveless, or Mouthpiece Ventec One-Circuits. Use of third-party patient circuits is considered off-label. Assemble Ventec One-Circuits and Ventec One-Circuit accessories using the procedures and sequences depicted in this manual.

NOTE: See *"Mouthpiece Patient Circuit Setup"* on page 30 for detailed setup instructions for that circuit type.

Ventec Life Systems offers single-patient use adult and pediatric Ventec One-Circuits for use with V*Home, which incorporate an optional passive exhalation valve, and an optional heated wire (for connection to a humidifier). See *"Accessories"* on page 204 for a list of Ventec One-Circuits available from Ventec Life Systems.

Each time the Ventec One-Circuit or its configuration is changed, or the Circuit Type control is modified, run a Pre-Use Test before initiating therapy. The Pre-Use Test will calculate the resistance, and leak of the Ventec One-Circuit to ensure Ventilation therapy is delivered accurately.

WARNING: Adding unauthorized attachments, components, or sub-assemblies to the Ventec One-Circuit can change the pressure gradient of the Ventec One-Circuit and adversely affect the performance of V*Home.

WARNING: Ventec One-Circuit accessories (including but not limited to filters, nebulizers, and humidifiers) may increase the resistance of the Ventec One-Circuit and affect the accuracy of delivered Ventilation therapy. Inspect all patient circuit filters frequently for signs of increased resistance or blockages, and ensure alarms are set appropriately to verify the accuracy of delivered Ventilation therapy.

WARNING: To reduce the risk of electric shock, do not use anti-static or electrically conductive patient circuits or hoses with the V*Home system. Only Ventec One-Circuits are approved for use with V*Home.

WARNING: To ensure patient safety, check the Ventec One-Circuit and verify that all system settings and Presets are appropriate before providing therapy, and on a routine basis during therapy.

WARNING: Any components added to the breathing circuit between the Ventec One-Circuit exhalation valve and the patient will increase the amount of gas that the patient rebreathes with each breath. The addition of components into the breathing circuit should be considered carefully, especially for small pediatrics.

NOTE: When providing non-invasive ventilation, use CO2 monitoring equipment compliant with ISO 80601-2-55 to ensure patient safety.

Ventec One-Circuits may be connected to a humidifier and/or other patient circuit components as needed. See *"Connecting Ventec One-Circuit Components"* on page 27 for detailed instructions.

Using a Trach, ET Tube, or Non-Vented Mask

V*Home may be connected to a non-vented mask, trach or ET tube to provide Ventilation therapy using a Passive Ventec One-Circuit. This circuit type includes an exhalation valve designed to expel exhaled gases. See the following pages for detailed setup instructions

Using a Vented Mask

V*Home may be connected to a vented mask to provide Ventilation therapy using a Valveless Ventec One-Circuit. Valveless circuits do not include an exhalation valve, and are designed for use with a mask patient interface incorporating a fixed leak. See the following pages for detailed setup instructions.

NOTE: Vented masks used with V*Home must be connected with a Valveless or Passive Ventec One-Circuit and have an integrated leak of 20 to 50 L/min at 10 cmH₂O to ensure proper device performance.

Using a High Flow Nasal Cannula

VOCSN may be connected to a high flow nasal cannula to provide High Flow therapy using a Valveless Ventec One-Circuit.

NOTE: When using a Valveless Ventec One-Circuit, leave the circuit connected to V*Home, and disconnect the mask or high flow nasal cannula while running the Pre-Use Test.

Connecting a Passive or Valveless Ventec One-Circuit

The Ventec One-Circuit comes with an optional passive exhalation valve, and an optional heated wire (for connection to a humidifier). The setup procedure will depend on the type of Ventec One-Circuit and the accessories used. To connect a Ventec One-Circuit to V*Home:

- 1** Connect a bacterial filter. See *"Connecting an External Bacterial Filter"* on page 25.
- 2** Connecting the Ventec One-Circuit depends on whether you are using an HME or a humidifier. Follow the instruction below the corresponds to the Ventec One-Circuit configuration:
 - To configure the Ventec One-Circuit with an HME instead of a humidifier, see *"Connecting an HME (Heat-Moisture Exchanger)"* on page 27.
 - To configure the Ventec One-Circuit with a humidifier, without connecting a Ventec Humidifier Bypass, see *"Connecting a Ventec One-Circuit to a Humidifier"* on page 26.
- 3** To attach other components to the Ventec One-Circuit, such as a nebulizer, see *"Connecting an External Nebulizer Cup to the Patient Circuit"* on page 28.
- 4** The diagram on the next page illustrates the Ventec One-Circuit and optional components in the correct configuration. Consult *"Ventec One-Circuit Component Connection Order"* on page 24 to verify that everything is connected in the correct order.

Ventec One-Circuit Component Connection Order

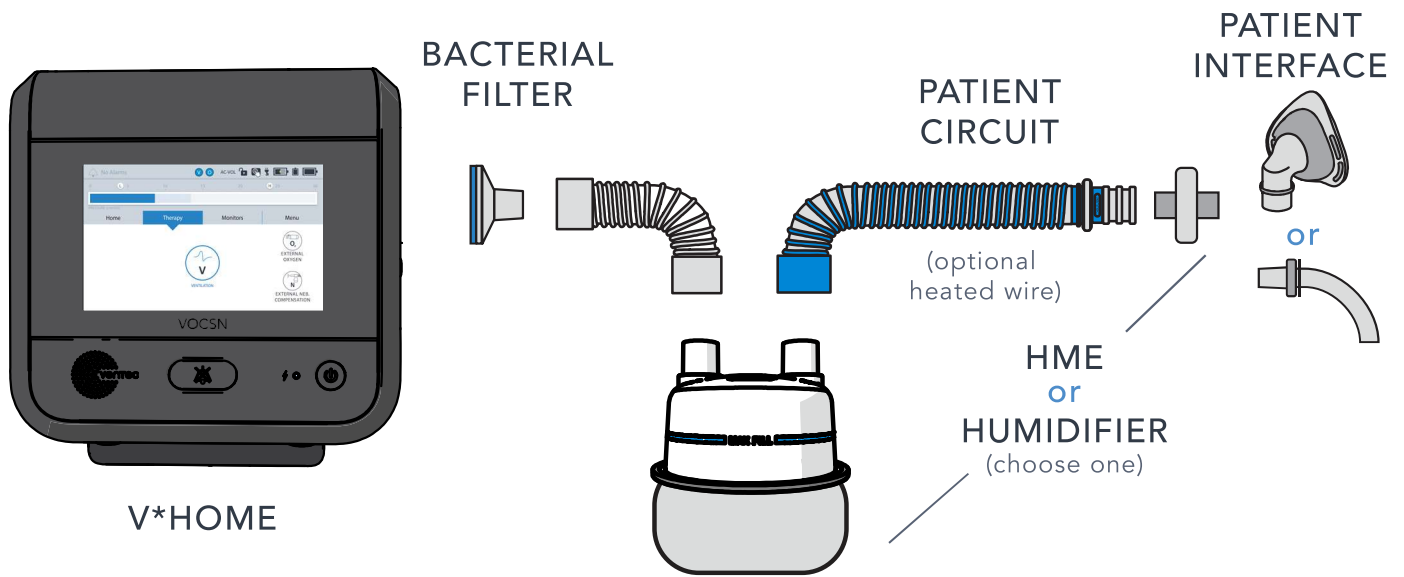

Item Name	Required?	Additional Information
VOCSN Bacterial Filter	Required	See <i>"Connecting an External Bacterial Filter"</i> on page 25 for instructions.
Humidifier	Optional	May include a form of humidification (either an HME or humidifier).
Ventec One-Circuit	Required	Use either a Passive, or Valveless Ventec One-Circuit. Ventec One-Circuits may include a heated wire. (For Mouthpiece Patient Circuit instructions, see <i>"Mouthpiece Patient Circuit Setup"</i> on page 30.)
Heat-Moisture Exchanger (HME)	Optional	May include a form of humidification (either an HME or humidifier). See <i>"Connecting an HME (Heat-Moisture Exchanger)"</i> on page 27 for instructions.
Patient interface	Required	Examples of a patient interface include a mask, trach, or ET tube. and Passive Ventec One-Circuits include an exhalation valve and are intended for use with non-vented masks, trach, or ET tubes. Valveless Ventec One-Circuits are intended for use with vented masks, or nasal cannulas for High Flow therapy.

Connecting an External Bacterial Filter

Connect an external bacterial filter to reduce the risk of cross-contamination. Attach a bacterial filter to the Ventec One-Circuit connection port before connecting a Ventec One-Circuit.

Fit the bacterial filter against V*Home, aligning the icons on the filter and V*Home, then twist the filter to lock it into place.

V*Home contains a secondary, internal bacterial filter to help protect against cross-contamination in case of external bacterial filter failure. The internal bacterial filter should be replaced whenever it may have become cross-contaminated, such as when the external bacterial filter becomes compromised, or if an infectious disease specialist recommends its replacement. See *“Replacing the Internal Bacterial Filter”* on page 130 for instructions.

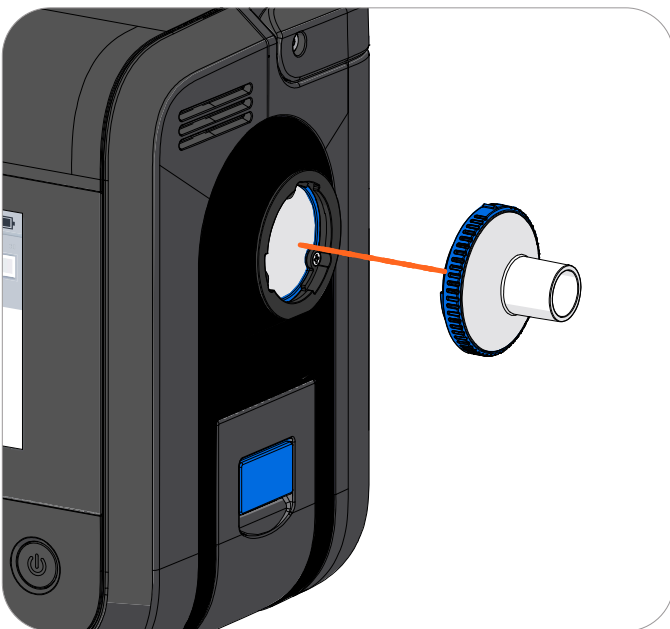

Connecting a Passive Ventec One-Circuit with HME

When not using a humidifier as part of the Ventec One-Circuit configuration, connect the circuit to the bacterial filter. Connect an HME to the Ventec One-Circuit to provide the patient with humidification, following the instructions in *“Connecting an HME (Heat-Moisture Exchanger)”* on page 27.

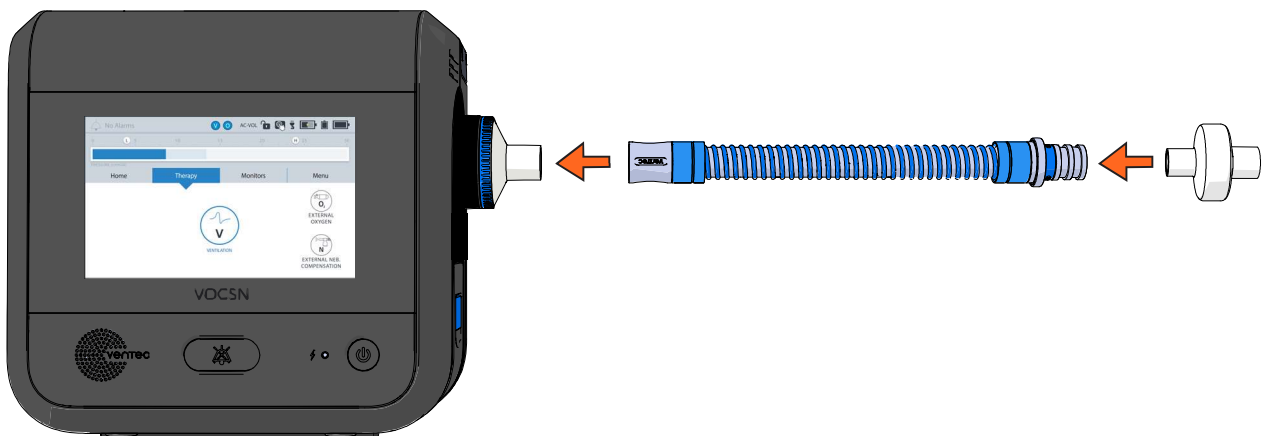

Connecting a Humidifier and Heated Wire Ventec One-Circuit

When using a humidifier, use a heated-wire Ventec One-Circuit to manage water condensation inside the Ventec One-Circuit. Place the humidifier below V*Home and the patient to prevent water from leaking into the patient.

WARNING: Do not use heated wire Ventec One-Circuits on, within, or under localized heat sources or insulating materials such as blankets or thermal chambers. External sources of heat or insulation may impair the performance of heated wire Ventec One-Circuits.

NOTE: Using humidifiers or other accessories not specified for use with this system may impair V*Home performance. Ventec Life Systems recommends use of the Fisher & Paykel HC550, the Fisher & Paykel MR850, or equivalent. Humidifiers connected to the Ventec One-Circuit should comply with ISO 8185.

Connecting a Ventec One-Circuit to a Humidifier

To connect a humidifier to the Ventec One-Circuit:

- 1** Connect a length of patient circuit tubing (sold separately) to the open end of the external bacterial filter. Connect the other end to the humidifier.
- 2** When connecting a heated wire Ventec One-Circuit to the humidifier, follow instructions from the humidifier manufacturer to connect heated wire and temperature sensor lines from the humidifier to the Ventec One-Circuit.

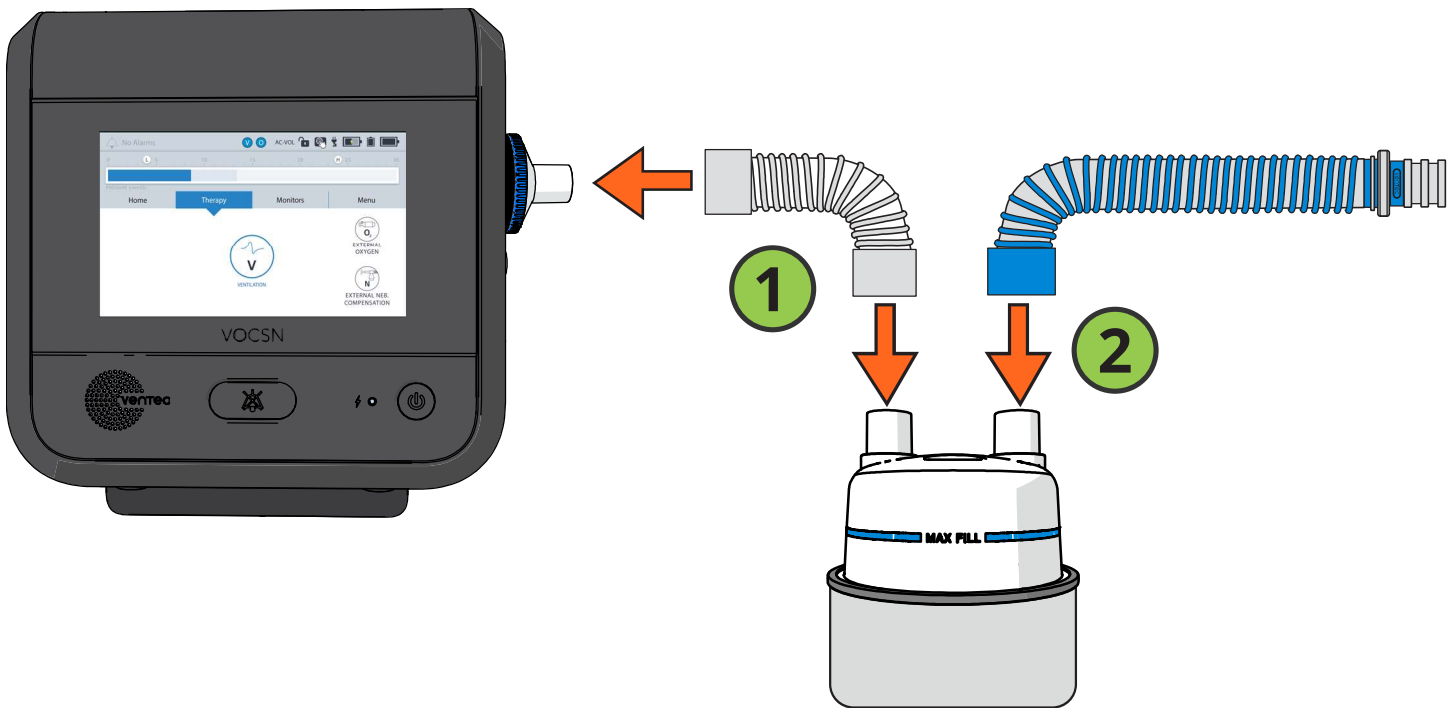

Connecting Ventec One-Circuit Components

If necessary, attach additional Ventec One-Circuit components, such as an HME, nebulizer, or closed-suction catheter to the Ventec One-Circuit. For setup instructions, see:

- “Connecting an HME (Heat-Moisture Exchanger)” on page 27
- “Connecting an External Nebulizer Cup to the Patient Circuit” on page 28

NOTE: Ventec Life Systems recommends including a humidifier or heat-moisture exchanger (HME) as part of passive and valveless Ventec One-Circuit configurations.

Connecting an HME (Heat-Moisture Exchanger)

If you’re not using a humidifier, you may connect an HME to the Ventec One-Circuit between the exhalation valve and the patient.

Follow all setup instructions provided by the HME manufacturer.

NOTE: Any HME attached to the V*Home Ventec One-Circuit should comply with ISO 9360-1 or ISO 9360-2.

NOTE: When used with a vented mask, exhaled, humidified air exits the mask instead of traveling through the HME, greatly reducing its efficacy.

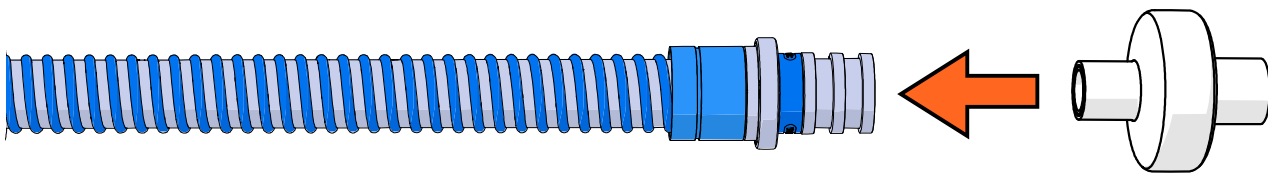

Connecting an External Nebulizer Cup to the Patient Circuit

The V*Home breathing system can be configured to compensate for the flow added to the patient circuit from an external 6 L/min nebulizer. Follow all instructions from the manufacturer to connect an external nebulizer cup to the patient circuit, and see *“Starting Nebulizer Compensation” on page 123* for instructions on compensating Ventilation therapy for the flow from an external 6 L/min nebulizer.

NOTE: To ensure proper device operation, all nebulizer parts connected to V*Home should comply with the relevant requirements of ISO 27427.

Follow all setup and operating instructions provided by the nebulizer manufacturer, including any indications for use or contraindications regarding fluid types for use with the nebulizer. The nebulizer should be disconnected between uses.

WARNING: Use only 6 L/min nebulizer cups with V*Home. V*Home ventilation compensates for 5.9 L/min of nebulizer flow while the nebulizer drive is active. When gas is added to the Ventec One-Circuit from a nebulizer producing a flow less or more than 6 L/min, the accuracy of delivered ventilation may be temporarily affected.

NOTE: During the brief period while Nebulizer therapy is running without the nebulizer connected to the patient circuit, delivered Tidal Volumes may be affected.

NOTE: If an HME is used, connect the nebulizer cup between the HME and the patient to prevent the HME from trapping nebulized medication.

NOTE: If a passive Ventec One-Circuit is used, Ventec Life Systems recommends connecting a filter between the distal end of the circuit and the nebulizer tee to ensure nebulized material does not collect in the passive valve and obstruct airflow.

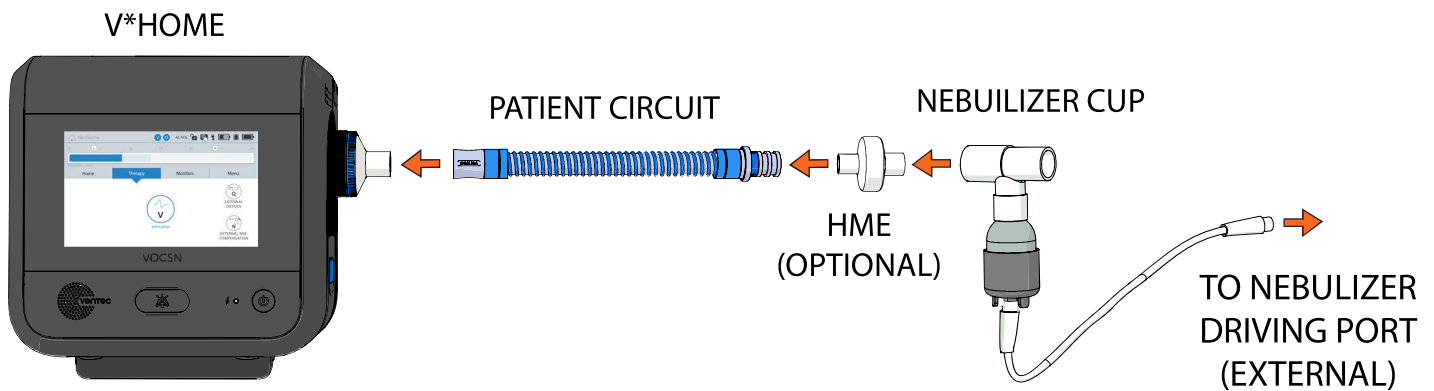

Setting up Ventilation Therapy with a Speaking Valve

V*Home may be used with a passive Ventec One-Circuit and/or a pressure ventilation mode and a connected speaking valve. Because gas delivered from V*Home exits the mouth rather than the Ventec One-Circuit, volume delivery may be affected when a passive Ventec One-Circuit is used. Therefore, volume ventilation modes with a passive Ventec One-Circuit and connected speaking valve is not recommended.

Gas exits through the mouth while speaking valve is in place rather than through the Ventec One-Circuit exhalation valve. This will cause the monitored Vte and Minute Volume to appear smaller than expected. In addition, the Leak monitor will likely appear larger than expected as the patient speaks. This may cause the activation of the Low Minute Volume or Patient Circuit Disconnect alarm.

WARNING: If the Low Minute Volume and/or Patient Circuit Disconnect alarm cannot be set appropriately for the patient condition because of a connected speaking valve or other reason, use an alternate respiratory monitor such as an oximeter or cardio-respiratory monitor to detect hypoventilation.

Mouthpiece Patient Circuit Setup

Mouthpiece patient circuits are recommended for use with patients who can place their mouths on the circuit to initiate breaths on their own.

WARNING: Using a mouthpiece for Ventilation is not recommended for patients <5 years of age, due to the requirements for physiological and neurological development, as well as neuromuscular coordination necessary for the application of effective therapy.

Setting the Circuit Type control to Mouthpiece will limit the available ventilation modes and controls to those that are suitable for use with this type of patient circuit. See *"Setting V*Home Controls for Mouthpiece Ventilation"* on page 71 for additional information.

To connect a mouthpiece patient circuit to V*Home, begin by connecting an external bacterial filter. Connect the Mouthpiece Circuit Kit components in the order depicted below.

- 1** Reducer cuff
- 2** 15mm circuit tubing (one piece)
- 3** Optional Mouthpiece Circuit Support Arm, available separately
- 4** Coupler
- 5** Flexible extension (optional)
- 6** Angled mouthpiece



Oxygen Therapy Setup

Oxygen therapy can be delivered to the patient using a connected external source of low-pressure oxygen to flow oxygen up to 25 L/min through V*Home and into the Ventec One-Circuit, via the low-pressure oxygen port.

NOTE: Do not bypass the oxygen ports in the back of V*Home to bleed oxygen directly into the Ventec One-Circuit from an external oxygen source. Any source of external oxygen used with V*Home should be connected to the appropriate port on the back of the device. Bleeding oxygen into the Ventec One-Circuit can adversely affect the efficacy of delivered therapy.

WARNING: If the patient's prescribing healthcare professional determines Oxygen therapy is critical to patient care, provide continuous monitoring, such as pulse oximetry or proximal FiO₂ monitoring.

Setting Up External Oxygen Sources

V*Home can be used with an external source of low-pressure. To ensure safe use of external oxygen sources, first verify the following:

- V*Home is not near open flame, ignited cigarettes, or flammable gases.
- V*Home is not connected to an unregulated oxygen source.
- External oxygen sources are connected to the proper port on the back of V*Home, not directly to the Ventec One-Circuit, and if possible, are turned off when not in use.
- The oxygen source meets the pressure or flow specification requirements described in *"Inputs and Outputs"* on page 153.

Connecting External Low-Pressure Oxygen

External low-pressure oxygen sources can be connected to V*Home to add oxygen into the Ventec One-Circuit. The flow of low-pressure oxygen is controlled by the oxygen source, not by the V*Home oxygen controls.

NOTE: The FiO2 Monitor and FiO2 alarms are not available while using an external source of low-pressure oxygen.¹ When an external low-pressure oxygen source is applied, use external O2 monitoring equipment (which may be included with the oxygen source) compliant with ISO 80601-2-55 to verify oxygen delivery before putting the system into service. To connect external O2 monitoring equipment to V*Home, follow all instructions provided by the monitoring equipment manufacturer.

NOTE: To prevent oxygen accumulation in and around the device, ensure the low-pressure oxygen source is off while V*Home is off.

To connect an external low-pressure oxygen source (e.g., oxygen concentrator or liquid oxygen):

- 1** Connect an O2 Low Pressure Inlet Adapter (available from Ventec Life Systems) to the low-pressure O2 port on the back of V*Home.
- 2** Connect the oxygen source to the adapter.
- 3** Follow all instructions from the low-pressure oxygen source manufacturer to begin providing Oxygen therapy. See *"Low-Pressure Oxygen Blending"* on page 178 for charts illustrating the expected FiO2 at various settings.

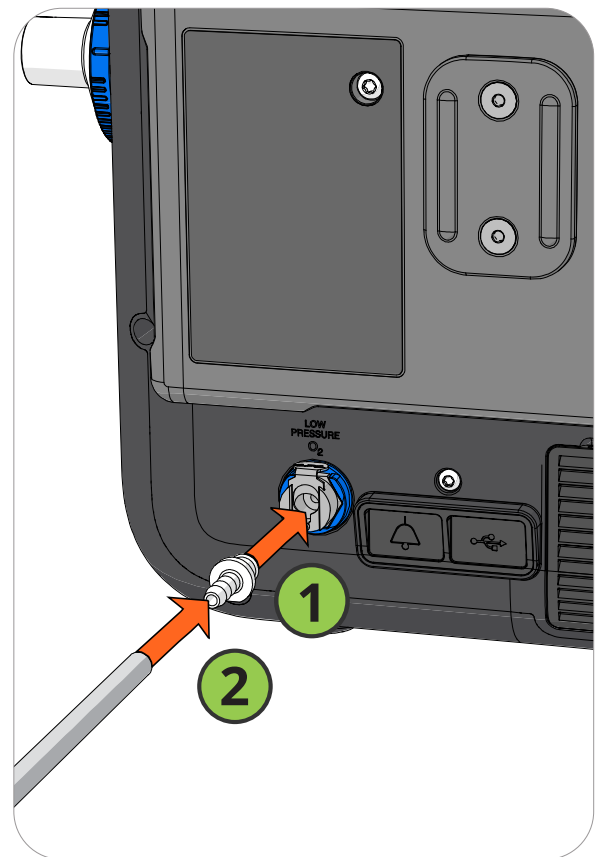

Connecting a Nurse Call System or Remote Alarm

The remote alarm port is behind a protective rubber flap on the back of V*Home. This port may be used to connect a remote alarm, a nurse call system, or other alarm systems that sense contact closure through a 1/4" phono jack. Only use the remote alarm port with Ventec Nurse Call cables or other cables approved by Ventec Life Systems. Follow all setup instructions provided by the remote alarm or nurse call system manufacturer.

If used with a remote alarm, position the remote alarm so that it can be heard by the clinician or caregiver at all times.

Always test the alarm immediately after installation, and periodically during use to ensure it is functioning as intended.

NOTE: Normally open nurse call systems may not cause an alarm condition when disconnected from V*Home. Follow all instructions provided with the nurse call system to ensure safe operation.

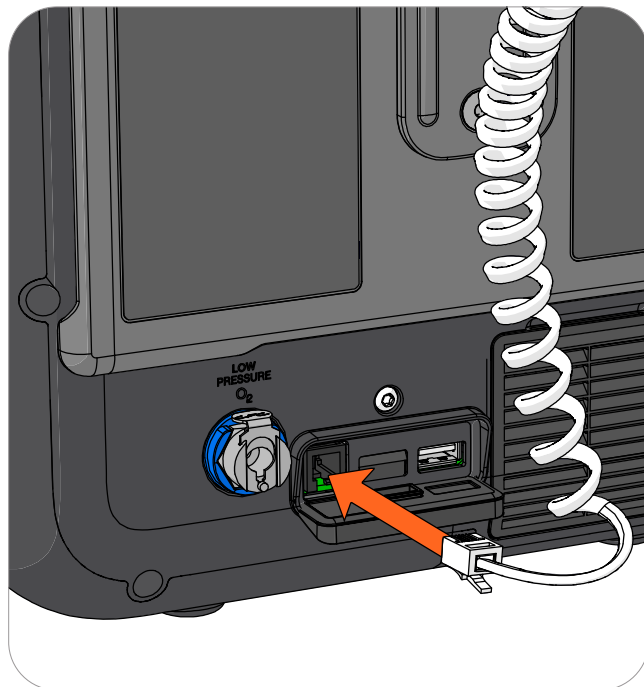

WARNING: To reduce the risk of electrical shock, ensure the Nurse Call System connected to V*Home meets the Safety Extra Low Voltage (SELV) requirements as described in IEC 60601-1 (1988).

Safety Extra-Low Voltage (SELV): Voltage which does not exceed nominal values of 25 VAC or 60 V DC at rated supply voltage on transformer or convert, between conductors in the earth-free circuit which is isolated from the supply mains by a safety extra low voltage transformer, or by a device with equivalent separation.

Safety Extra-Low Voltage Transformer: Transformer with an output-winding which is electrically separated from earth and the body of the transformer by at least basic insulation and which is electrically separated from the input winding by an insulation at least equivalent to double insulation or reinforced insulation and which is designed to supply Safety Extra-Low Voltage circuits.

WARNING: To reduce the risk of electrical shock in the event of a failure of Nurse Call System's electrical separation from supply mains, operator should not simultaneously touch the patient and any exposed metal on the V*Home rear housing, including: the DC power connector shell, either high or low pressure oxygen connectors, and/or the exposed metal screw above the Nurse Call/USB port.

Running the Pre-Use Test

The V*Home Pre-Use Test calculates the resistance and leak of the Ventec One-Circuit. Based on these calculations, V*Home verifies the integrity of the Ventec One-Circuit, and also improves the accuracy of therapy delivered during ventilation.

To ensure therapy is delivered accurately, you must perform a Pre-Use Test whenever prompted, the patient circuit is changed, or the device is powered on.

WARNING: Ventilation therapy is paused during the Pre-Use Test. If Ventilation therapy is critical to patient care, provide backup ventilation for the duration of the test. To ensure patient safety, always verify Ventilation therapy is resumed when the Pre-Use Test is complete.

NOTE: Though accuracy may be reduced, V*Home may still be used to provide ventilation therapy when the Pre-Use Test fails. If time constraints make running the test inadvisable, press the **EXIT** button to immediately initiate Ventilation therapy.

NOTE: To calculate resistance correctly, the Pre-Use Test must be performed without an HME connected to the Ventec One-Circuit.

Some control changes cause V*Home to prompt you to run a Pre-Use Test. You may also press the **Menu** tab and then the **PRE-USE TEST** button to begin a Pre-Use Test at any time.

To run a Pre-Use Test, carefully follow the on-screen instructions. When instructed, use a clean, gloved hand to obstruct the circuit completely, as follows:

- If you are using a Passive, or Valveless Ventec One-Circuit, disconnect the patient interface and block the circuit at its end.
- If you are using a Mouthpiece patient circuit, leave the mouthpiece connected, and block the open end.

If the test completes successfully, reconnect the Ventec One-Circuit to the patient and resume Ventilation therapy. If the test fails, inspect the Ventec One-Circuit configuration for leaks or improper setup. Resolve any issues with the Ventec One-Circuit, and then press **RESTART** to run the Pre-Use Test again.



Connecting a React DataLink™

The optional React DataLink enables wireless access to V*Home data. The data can be accessed on the Multi-View Connect™ portal at multiviewconnect.venteclife.com. Consult the React DataLink and Multi-View Connect IFU for detailed instructions on device function and connection.

Note: Velcro strips must not obscure the label on the back of V*Home.

Note: Only V*Home software versions 5.00.09 or newer are compatible with the React DataLink.

Note: Make sure to adjust the V*Home Date and Time settings to your local date and time. Refer to the Device Settings section for instructions on how to complete this action.



Breath Types and Therapy Modes

Breath Types

Breaths can be initiated (started) and cycled (ended) by either V*Home or the patient. Depending on the Ventilation Mode and breath control settings chosen, V*Home may provide the patient with mandatory, assist, or spontaneous breaths.

Breath	Triggered by	Cycled by	Description
Mandatory	V*Home	V*Home	Mandatory breaths are initiated by V*Home based on the set Breath Rate and delivered as pressure or volume breaths. Breaths cycle at the end of the set Inspiratory Time. If Pressure Control Flow Termination is enabled, mandatory breaths may be cycled by the patient when the flow drops to the set Flow Cycle percentage.
Assist	Patient	V*Home	Assist breaths are initiated by the patient and delivered as pressure or volume breaths. Breaths cycle when they reach the end of the set Inspiratory Time. If Pressure Control Flow Termination is enabled, breaths may be cycled by the patient when the flow drops to the set Flow Cycle percentage.
Spontaneous	Patient	Patient	Spontaneous breaths are initiated and cycled by patient effort.

Depending on the Ventilation Mode setting, mandatory and assist breaths may be delivered to the patient as either pressure or volume breath types. When triggered, spontaneous breaths provide a set pressure to support patient demand.

NOTE: When used with passive or valveless Ventec One-Circuits, V*Home was designed for use with a humidifier or HME. All volumes and flows are expressed in BTPS unless stated otherwise.

Pressure Breaths

Mandatory and assist breaths are delivered as pressure breaths in pressure ventilation modes. V*Home delivers pressure breaths by elevating the pressure of the Ventec One-Circuit to the set Pressure Control limit for the set Inspiratory Time.

NOTE: The maximum pressure delivered is limited to the High Pressure alarm setting minus 3 cmH₂O.

V*Home will deliver flow during the set Inspiratory Time to reach and maintain the set Pressure Control limit. Adjusting the Rise Time control will modify the rate of flow and rate of pressure elevation.

Pressure breaths cycle at the end of the set Inspiratory Time, or when flow drops to the set Flow Cycle percentage of peak flow when PC Flow Termination is set to On.

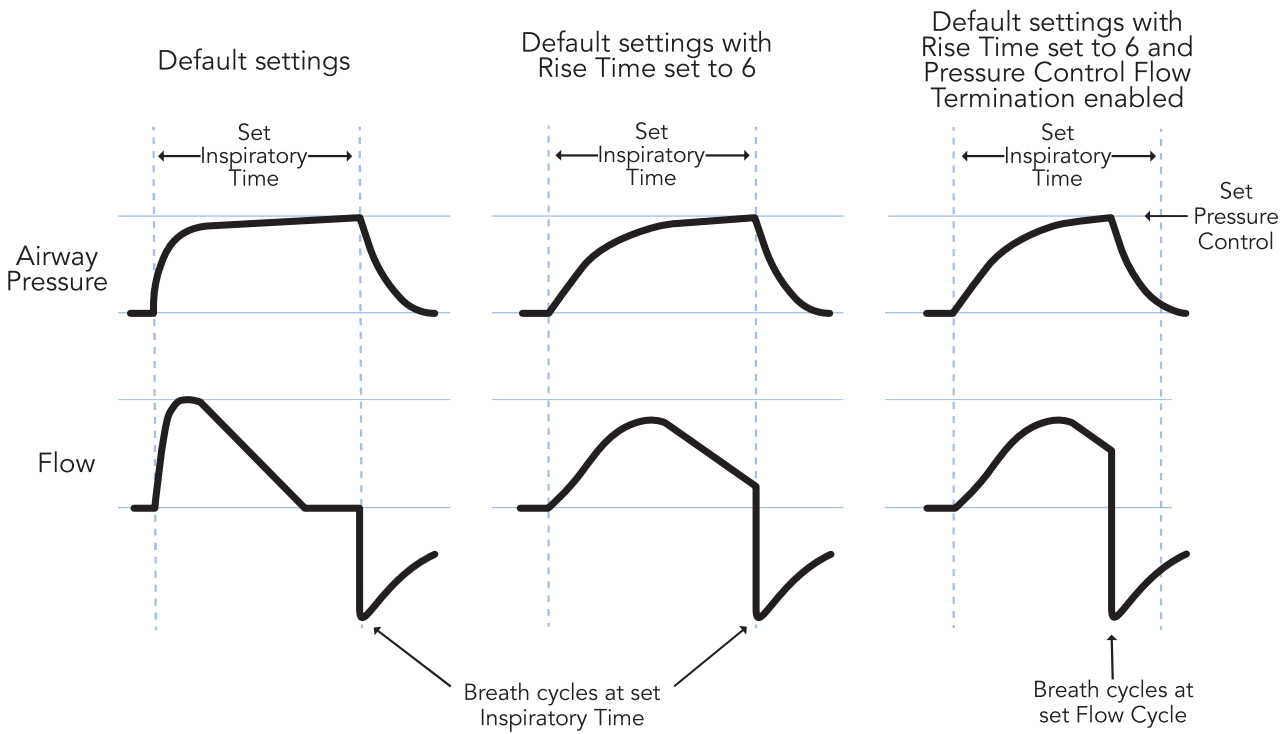

Volume Breaths

Mandatory and assist breaths are delivered as volume breaths in volume ventilation modes. Volume breaths deliver the set Tidal Volume over the set Inspiratory Time. Airway pressure is a function of patient lung resistance and compliance.

NOTE: Delivery of volume breaths to patients with extremely high airway resistance (e.g., 200 cmH₂O/L/s) and lung compliance requires high circuit pressure, which may cause the High Pressure alarm to activate before the target tidal volume is reached.

The set Tidal Volume and Inspiratory Time determine the peak flow (limited to 120 L/min). The final flow will be 50% of the peak flow, unless peak flow is below 20 L/min. When peak flow is below 20 L/min, the final flow will be 10 L/min.

Volume breaths cycle at the end of the set Inspiratory Time.

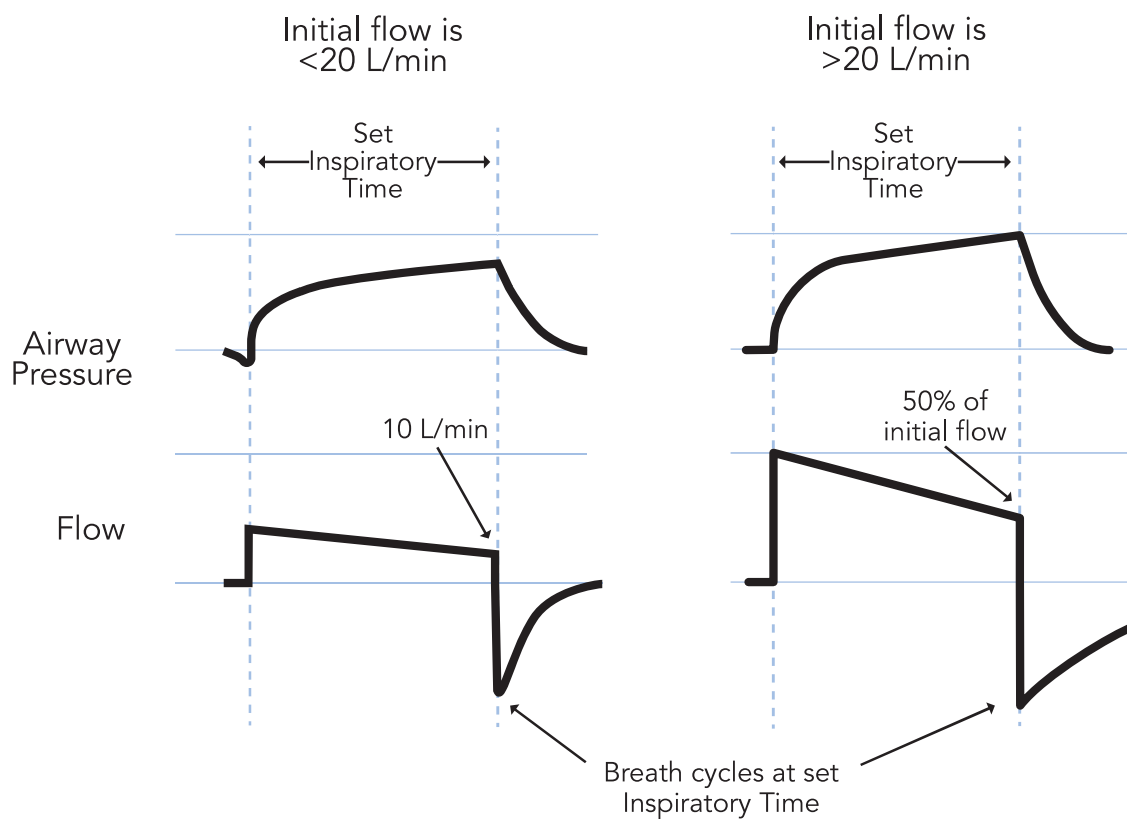

Spontaneous Breaths

Spontaneous breaths are initiated and cycled by the patient. Depending on the set Ventilation Mode, spontaneous breaths will be delivered at a set IPAP (in Bi-Level and Spontaneous modes) or at a set Pressure Support (in SIMV modes). Spontaneous breaths cycle at the set Flow Cycle percentage of peak flow, or at the Time Cycle setting, whichever is reached first.

V*Home Ventilation Modes

V*Home offers nine configurable Ventilation Mode settings: Bi-Level, Spontaneous, Assist/Control-Pressure, Assist/Control-Volume, SIMV-Pressure, SIMV-Volume, Vol. Targeted-PS, Vol. Targeted-PC, and Vol. Targeted-SIMV.

A breath period is the window of time used by V*Home to determine when mandatory breaths will be delivered to the patient. A breath period is 60 seconds divided by the set Breath Rate. Breath periods begin at the start of a breath, whether patient-triggered or mandatory.

Bi-Level Mode

Bi-Level mode provides the patient with two configurable levels of pressure: IPAP (above ambient) during inhalation, and EPAP during exhalation.

NOTE: Bi-Level ventilation is not intended for use with Mouthpiece patient circuits.

In Bi-Level therapy, the patient may initiate a spontaneous breath at any time at the set Flow Trigger. If the patient does not initiate a spontaneous breath within a breath period, V*Home will deliver a mandatory pressure breath to ensure the patient breathes at a minimum rate, set using the Breath Rate control.

Both spontaneous and mandatory breaths will be delivered at the set IPAP (above ambient). When a breath cycles, V*Home will deliver the set EPAP.

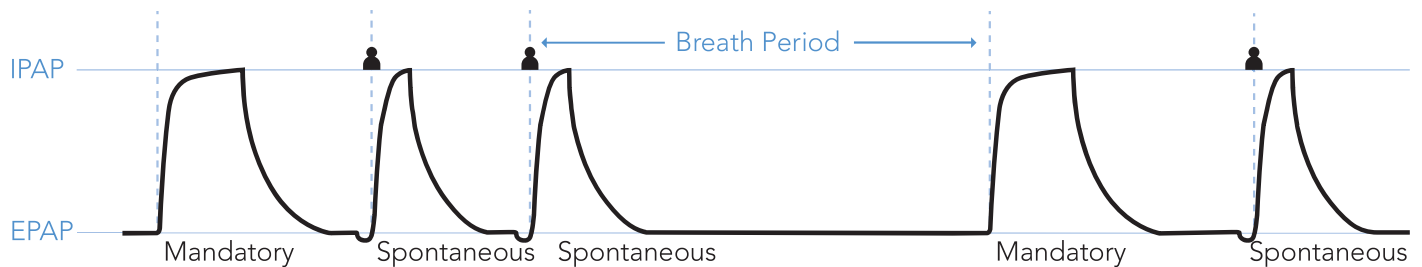

Spontaneous Mode

Spontaneous mode is used with mouthpiece patient circuits only. All breaths are spontaneous (initiated and cycled by the patient). When V*Home detects patient effort through the mouthpiece patient circuit, the set IPAP (above ambient) is delivered. When a breath cycles, the pressure of the patient circuit drops to zero (ambient).

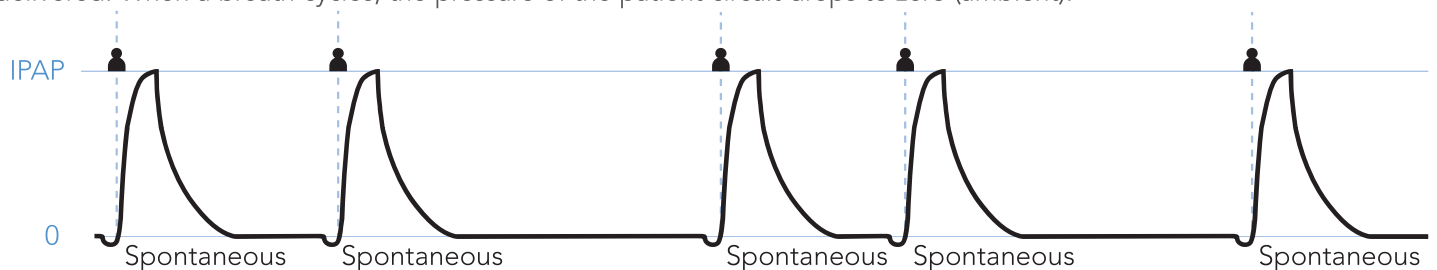

Assist/Control-Pressure Mode

Assist/Control-Pressure works one way with passive and valveless circuits, and differently when V*Home is connected to and configured to use a mouthpiece Ventec One-Circuit.

Assist/Control-Pressure with a Passive, or Valveless Ventec One-Circuit

When used with a passive, or valveless Ventec One-Circuit, Assist/Control-Pressure mode provides mandatory and assist pressure breaths, depending on the timing of detected patient effort. Patient effort will trigger an assist pressure breath. If no patient effort is detected within a breath period, V*Home will provide a mandatory pressure breath.

Both mandatory and assist breaths are delivered at the set Pressure Control (above PEEP)¹ over the set Inspiratory Time. When a breath cycles, the pressure of the Ventec One-Circuit drops to the set PEEP.

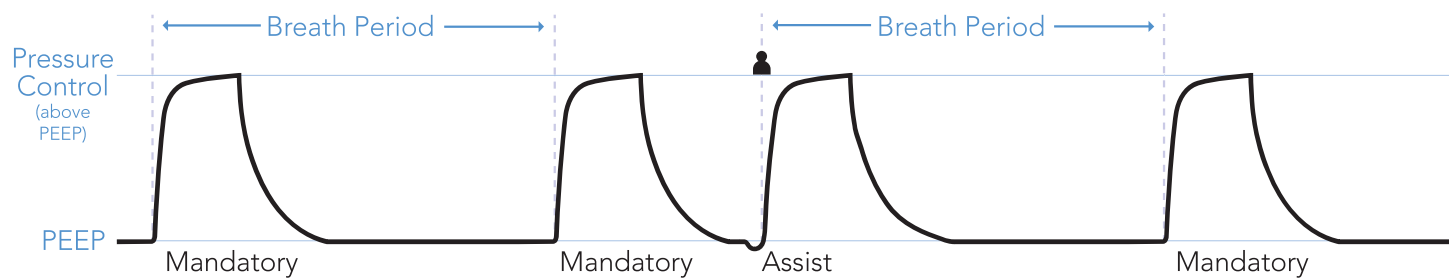

Assist/Control-Pressure with a Mouthpiece Patient Circuit

When used with a mouthpiece patient circuit, Assist/Control-Pressure mode provides assist pressure breaths when patient effort is detected.

Assist breaths are delivered at the set Pressure Control over the set Inspiratory Time. Since mouthpiece circuits are not always held in the mouth, the pressure of the patient circuit drops to zero when a breath cycles.

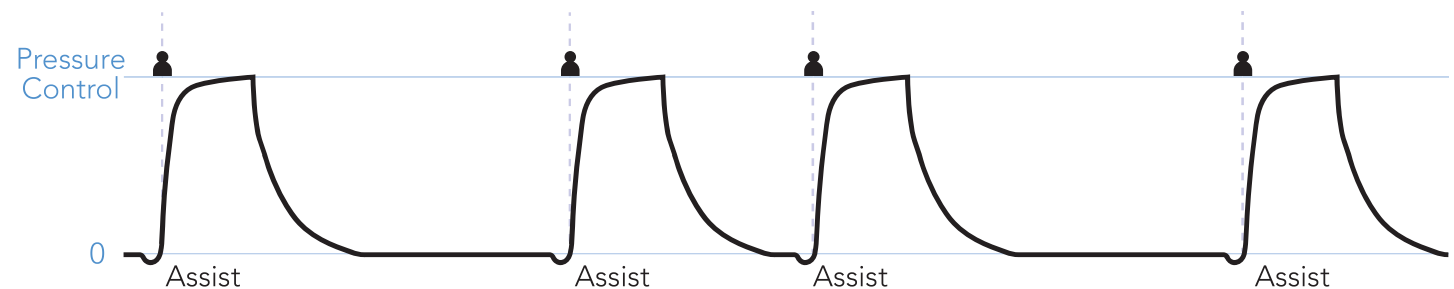

¹ In Assist/Control-Pressure mode, the peak pressure delivered is the set Pressure Control plus the set PEEP. Set the Pressure Control to the prescribed pressure to be delivered during inspiration, as an addition to the set PEEP. For example, a PEEP setting of 5 cmH₂O and Pressure Control setting of 10 cmH₂O will result in a peak pressure of 15 cmH₂O.

SIMV-Pressure Mode

SIMV-Pressure mode delivers pressure and spontaneous breaths through a passive, or valveless circuit. When patient effort is detected during a breath period, one assist breath will be delivered. Subsequent patient triggers within a breath period will result in spontaneous breaths.

If patient effort is not detected during a breath period, V*Home will provide a mandatory pressure breath at the beginning of the next breath period.

Both mandatory and assist breaths are delivered at the set Pressure Control (above PEEP),² over the set Inspiratory Time. Spontaneous breaths are delivered at the set Pressure Support (above PEEP), and cycle with patient effort. When a breath cycles, the pressure of the Ventec One-Circuit drops to the set PEEP.

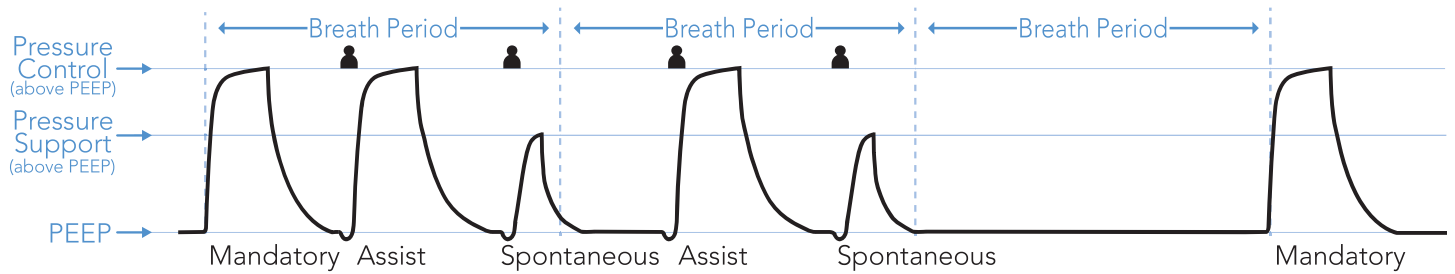

CPAP Function

V*Home does not include a separate mode setting for CPAP. The CPAP function is achieved by setting the ventilator to SIMV-Pressure (or SIMV-Volume) mode, and setting the Breath Rate and Pressure Support to zero. All breaths are spontaneous, and are delivered at the set PEEP level.

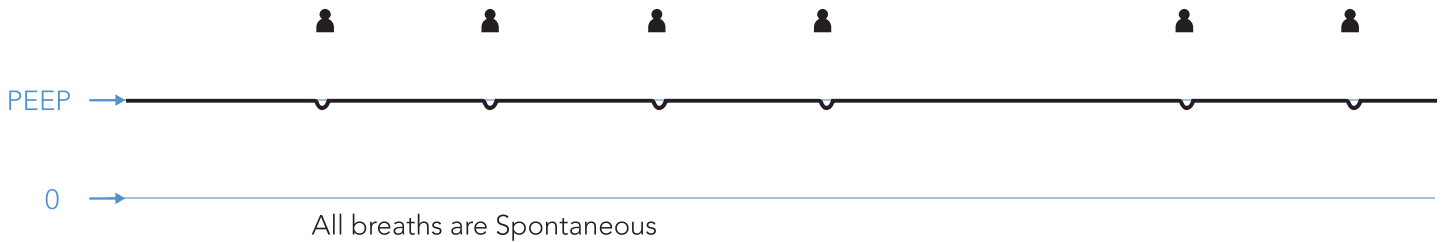

High Flow Therapy

When the Mode control is set to a SIMV mode, a High Flow option is available to provide the patient with a set flow of gas through a high flow nasal cannula or other interface. High Flow therapy is not intended for life support. Like the CPAP function in SIMV modes, there is no set Breath Rate and all breaths are spontaneous.

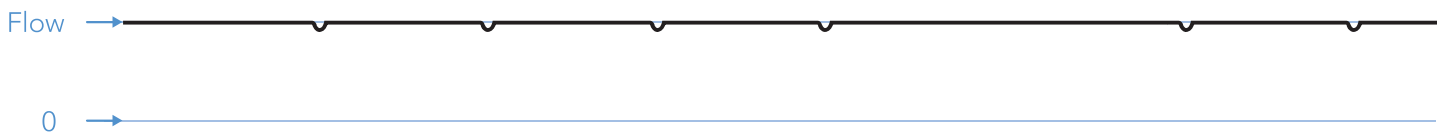

² In SIMV-Pressure mode, the peak pressure delivered during pressure breaths is the set Pressure Control plus the set PEEP. The peak pressure delivered during spontaneous breaths is the set Pressure Support plus the set PEEP. Set the Pressure Control and Pressure Support to the prescribed pressure to be delivered during inspiration, as an addition to the set PEEP. For example, a PEEP setting of 5 cmH₂O and Pressure Control setting of 10 cmH₂O will result in a peak pressure of 15 cmH₂O for pressure breaths.

Assist/Control-Volume Mode

Assist/Control-Volume works one way with passive and valveless circuits, and differently when V*Home is connected to and configured to use a mouthpiece Ventec One-Circuit.

Assist/Control-Volume with a Passive, or Valveless Ventec One-Circuit

When used with a passive, or valveless Ventec One-Circuit, Assist/Control-Volume mode provides mandatory and/or assist volume breaths. Patient effort will trigger an assist volume breath. If no patient effort is detected within a breath period, V*Home will provide a mandatory volume breath.

Both mandatory and assist breaths deliver the set Tidal Volume over the set Inspiratory Time. When a breath cycles, the pressure of the Ventec One-Circuit drops to the set PEEP.

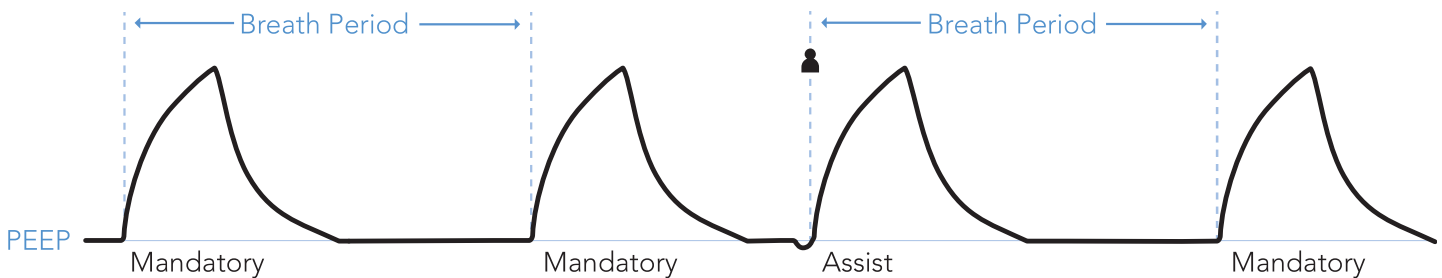

Assist/Control-Volume with a Mouthpiece Patient Circuit

When used with a mouthpiece patient circuit, Assist/Control-Volume mode provides assist volume breaths when patient effort is detected.

Assist breaths deliver the set Tidal Volume over the set Inspiratory Time. When a breath cycles, the pressure of the patient circuit drops to zero.

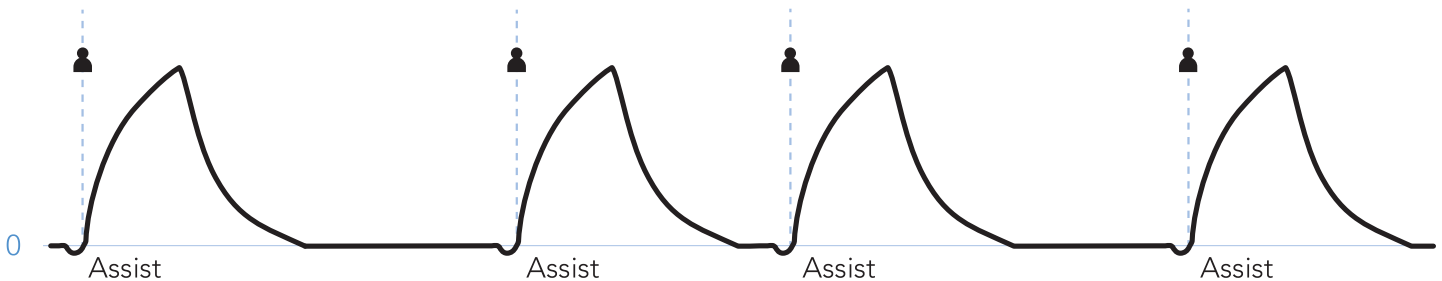

SIMV-Volume Mode

SIMV-Volume mode delivers volume and spontaneous breaths through a passive or valveless Ventec One-Circuit. When patient effort is detected during a breath period, one assist breath will be delivered. Subsequent patient triggers within a breath period will result in spontaneous breaths.

If patient effort is not detected during a breath period, V*Home will provide a mandatory volume breath at the beginning of the next breath period.

Both mandatory and assist breaths deliver the set Tidal Volume over the set Inspiratory Time. Spontaneous breaths are delivered at the set Pressure Support plus PEEP,³ and cycle with patient effort. When a breath cycles, the pressure of the Ventec One-Circuit drops to the set PEEP.

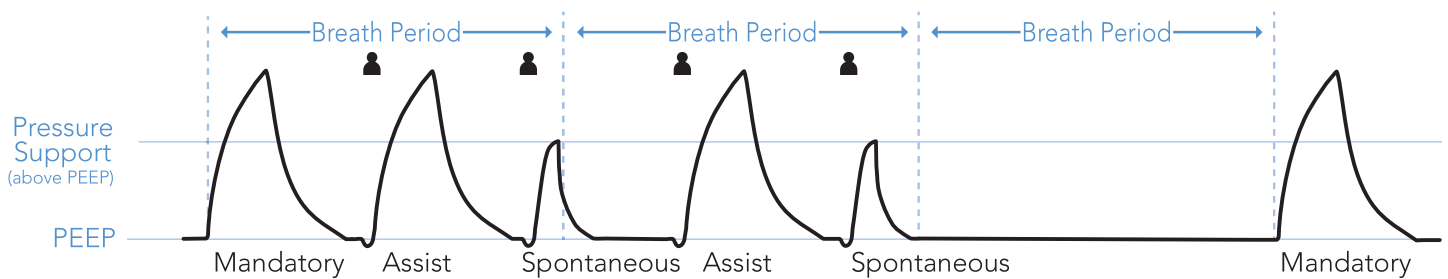

CPAP Function

V*Home does not include a separate mode setting for CPAP. The CPAP function is achieved by setting the ventilator to SIMV-Volume (or SIMV-Pressure) mode, and setting the Breath Rate and Pressure Support to zero. All breaths are spontaneous, and are delivered at the set PEEP level.

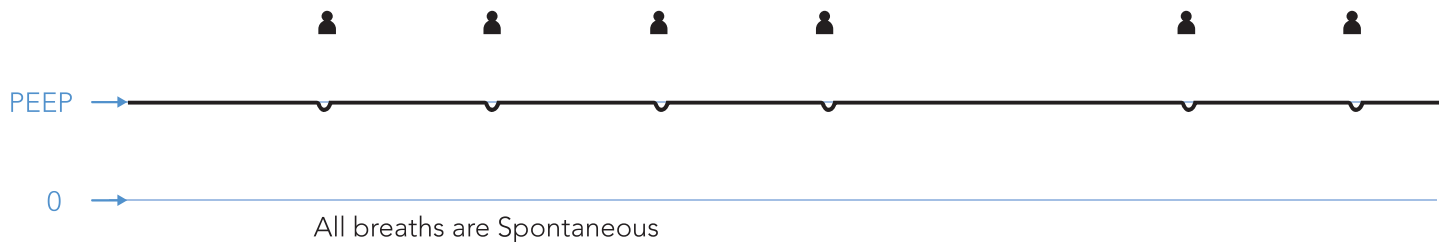

High Flow Therapy

When the Mode control is set to a SIMV mode, a High Flow option is available to provide the patient with a continuous, set flow of gas through a high flow nasal cannula or other interface. High Flow therapy is not intended for life support. Like the CPAP function in SIMV modes, there is no set Breath Rate and all breaths are spontaneous.

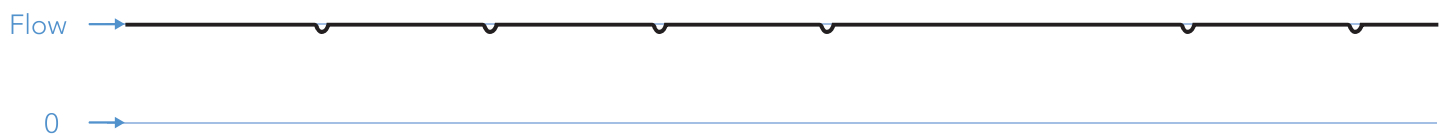

Volume Targeted Ventilation Overview

The Volume Targeted ventilation modes deliver a set Tidal Volume to the patient by adjusting the pressure control target on a breath-to-breath basis. These modes may be useful in maintaining consistent volume delivery in the face of changing patient conditions such as compliance.

In Volume Targeted modes, V*Home delivers a an initial breath to the patient, and then automatically adjusts the therapy to achieve and maintain the target Tidal Volume. The first breath is delivered as a pressure control breath at the set Pres. Minimum. V*Home then measures and calculates the pressure required to deliver the set Tidal Volume to the patient for subsequent breaths.

With each breath, V*Home makes adjustments to the delivered pressure to achieve the target Tidal Volume. The adjustment rate can be set using the Pres. Adj. Rate control. Setting the Pres. Adj. Rate control to Slow will increment breaths by up to ± 1 cmH₂O per breath. The Fast setting will increment breaths by up to ± 3 cmH₂O per breath.

NOTE: V*Home will pause calculations during activation of the High Pressure, Check Patient Circuit, or Patient Circuit Disconnect alarm, and then resume them once the alarm is resolved.

During Volume Targeted ventilation, the delivered pressure is limited to 5 cmH₂O below the High Pressure alarm setting, or 50 cmH₂O (whichever is less).

NOTE: In some cases, the High Pressure limit may prevent V*Home from delivering the entirety of the set Tidal Volume to the patient. Ventec Life Systems recommends using the Low Minute Volume alarm as a way to detect this condition.

NOTE: The Pres. Minimum setting may cause V*Home to deliver more volume than intended by the Tidal Volume setting. Ventec Life Systems recommends using the High Minute Volume alarm to detect this condition.

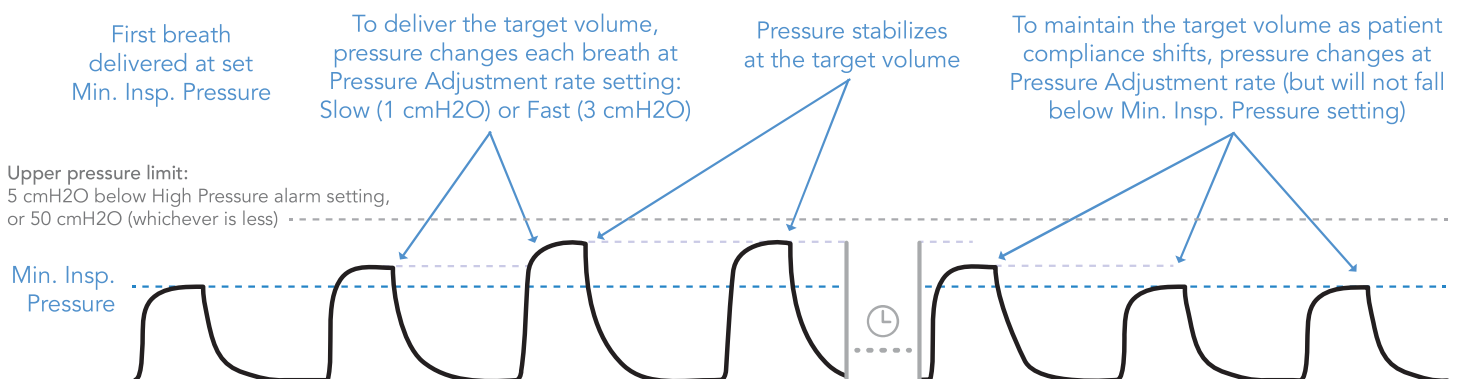

Vol. Targeted-PS Mode

Vol. Targeted-PS is a Volume Targeted mode of ventilation. The patient may initiate a spontaneous breath at any time. It provides the patient with two configurable levels of pressure: the set PEEP, and the pressure required to maintain the set Tidal Volume target.

Vol. Targeted-PS with a Passive, or Valveless Ventec One-Circuit

When used with a passive, or valveless Ventec One-Circuit, Vol. Targeted-PS mode allows the patient to initiate a spontaneous breath at any time at the set Flow Trigger. If the patient does not initiate a spontaneous breath within a breath period, V*Home will deliver a mandatory breath to ensure the patient breathes at a minimum rate, set using the Breath Rate control.

Both spontaneous and mandatory breaths are delivered and adjusted on a breath-to-breath basis to achieve and maintain the target Tidal Volume. When a breath cycles, V*Home will deliver the set PEEP.

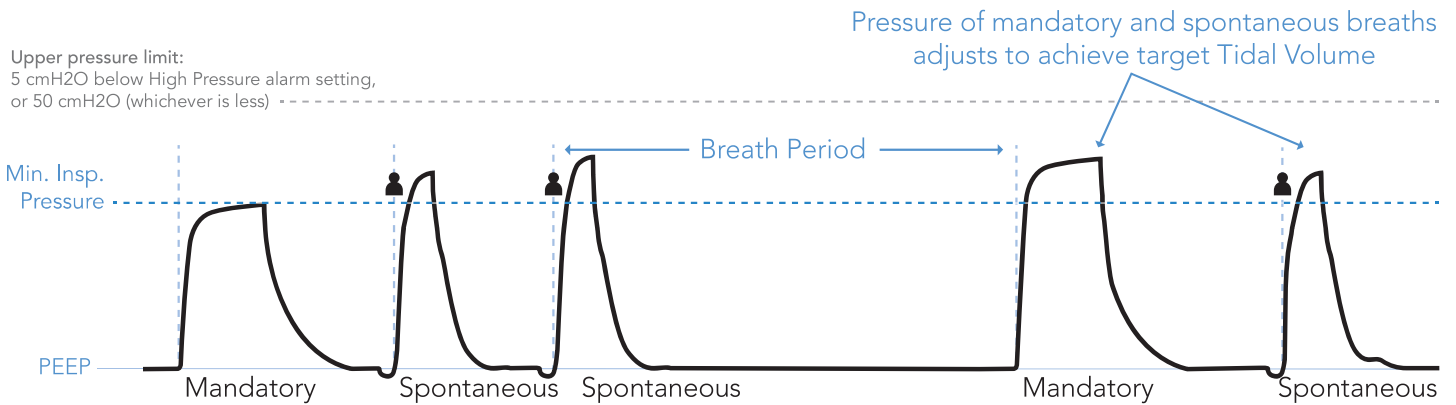

Vol. Targeted-PS with a Mouthpiece Patient Circuit

During ventilation with a Mouthpiece patient circuit, all breaths are spontaneous (initiated and cycled by the patient). When V*Home detects patient effort through the mouthpiece patient circuit, pressure is delivered and adjusted each breath to achieve the target Tidal Volume. When a breath cycles, the pressure of the mouthpiece patient circuit drops to zero (ambient).

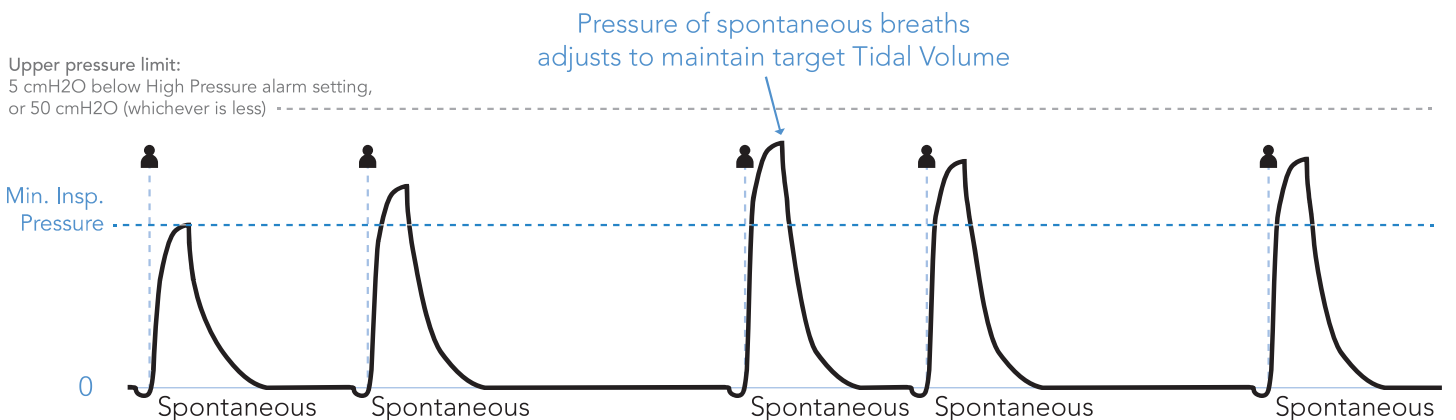

Vol. Targeted-PC Mode

Vol. Targeted-PC with a Passive or Valveless Ventec One-Circuit

When used with a passive or valveless Ventec One-Circuit, Vol. Targeted-PC mode provides mandatory and assist pressure breaths, depending on the timing of detected patient effort. Patient effort will trigger an assist pressure breath. If no patient effort is detected within a breath period, V*Home will provide a mandatory pressure breath.

Both mandatory and assist breaths are delivered and adjusted on a breath-to-breath basis to achieve and maintain the target Tidal Volume. When a breath cycles, the pressure of the Ventec One-Circuit drops to the set PEEP.

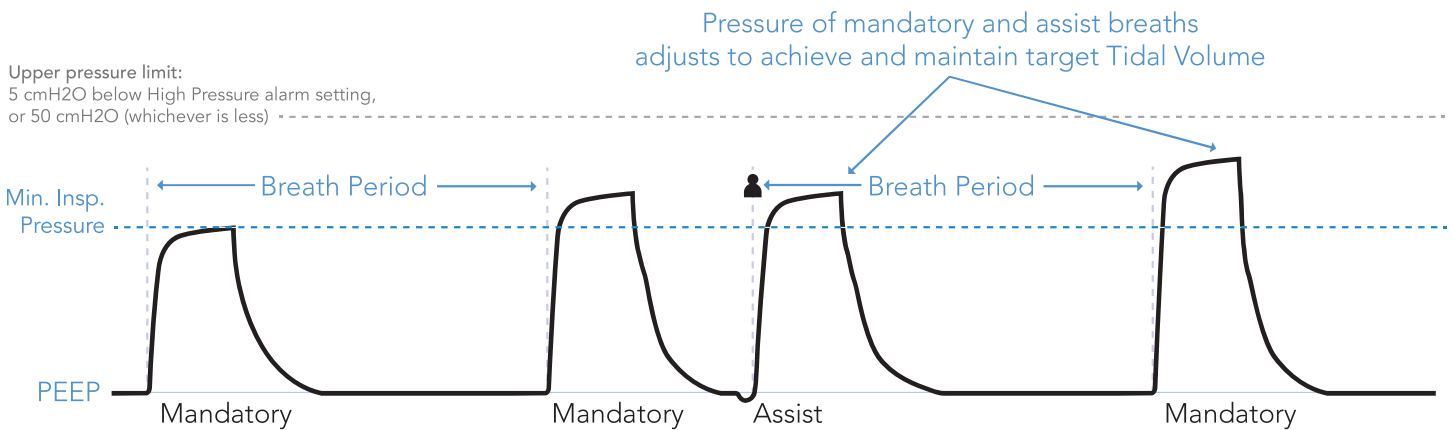

Assist/Control-Pressure with a Mouthpiece Patient Circuit

When used with a mouthpiece patient circuit, Vol. Targeted-PC mode provides assist pressure breaths when patient effort is detected.

Assist breaths are delivered and adjusted on a breath-to-breath basis to achieve and maintain the target Tidal Volume over the set Inspiratory Time. When a breath cycles, the pressure of the mouthpiece patient circuit drops to zero (ambient).

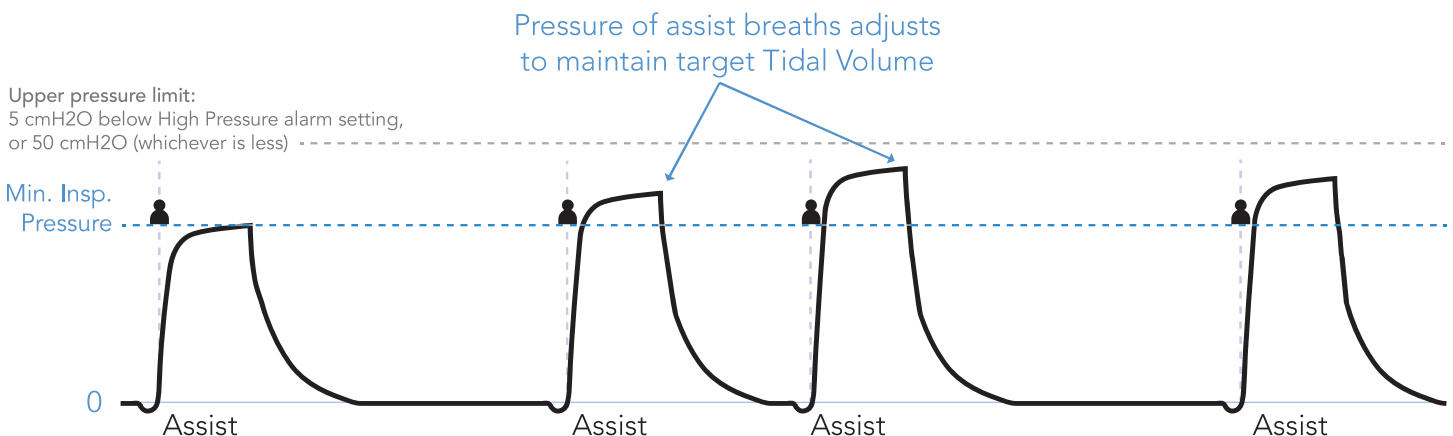

Vol. Targeted-SIMV Mode

Vol. Targeted-SIMV mode delivers volume targeted breaths through a passive or valveless circuit. When patient effort is detected during a breath period, one assist breath will be delivered. Subsequent patient triggers within a breath period will result in spontaneous breaths.

If patient effort is not detected during a breath period, V*Home will provide a mandatory pressure breath at the beginning of the next breath period.

Both mandatory and assist breaths are delivered and adjusted to achieve the set Tidal Volume, over the set Inspiratory Time. Spontaneous breaths are delivered at the set Pressure Support (above PEEP), and cycle with patient effort. When a breath cycles, the pressure of the Ventec One-Circuit drops to the set PEEP.

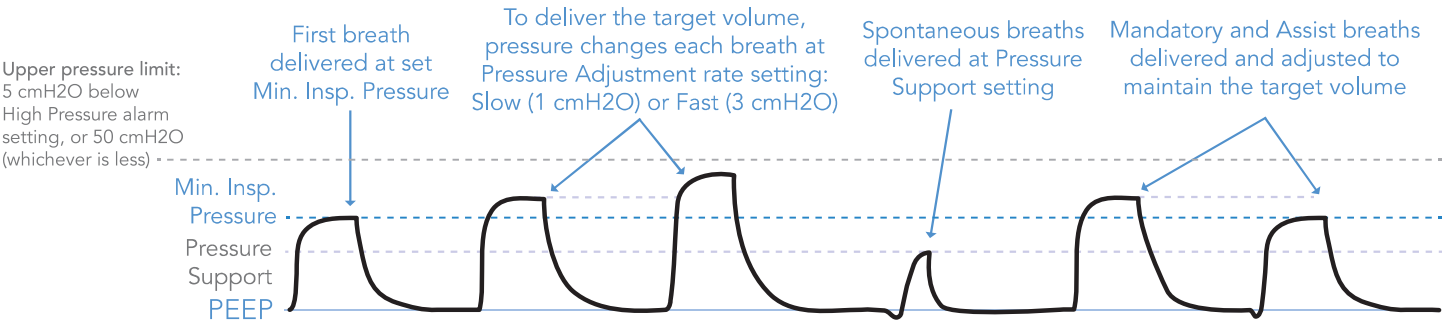

Comparable Ventilation Modes

The V*Home critical care ventilator provides a comprehensive set of ventilation modes to meet patient needs during invasive, non-invasive and mouthpiece ventilation. The reference list below illustrates how to set your preferred ventilation mode.

Comparable Volume Ventilation Modes

Ventilation Mode or Feature	Equivalent V*Home Mode Settings	Additional V*Home Controls
AC-Volume (Assist/Control) VC (Volume Control)	<ul style="list-style-type: none"> • Set Mode to AC-Volume • Set Breath Rate • Set Flow Trigger to On 	<ul style="list-style-type: none"> • Inspiratory time • Tidal Volume • PEEP • Sigh
SIMV-Volume or SIMV (Synchronized Intermittent Mandatory Ventilation) +/- Pressure Support	<ul style="list-style-type: none"> • Set Mode to SIMV-Volume • Set Breath Rate • Set Flow Trigger • Set Pressure Support (measured above the set PEEP) 	<ul style="list-style-type: none"> • Inspiratory Time • Tidal Volume (for mandatory breaths) • PEEP • Flow Cycle • Time Cycle • Rise Time • Apnea Rate • Sigh
CV-Volume (Control Ventilation)	<ul style="list-style-type: none"> • Set Mode to AC-Volume • Set Breath Rate • Set Flow Trigger to Off 	<ul style="list-style-type: none"> • Inspiratory time • Tidal Volume • PEEP • Sigh

Comparable Pressure Ventilation Modes (Including Volume-Targeted Ventilation)

Ventilation Mode or Feature	Equivalent V*Home Mode Settings	Additional V*Home Controls
AC-Pressure (Assist/Control) PC (Pressure Control)	<ul style="list-style-type: none"> Set Mode to AC-Pressure Set Breath Rate Set Flow Trigger 	<ul style="list-style-type: none"> Inspiratory Time PEEP Pressure Control (measured above the set PEEP) Pressure Control Flow Termination Flow Cycle Rise Time
PRVC (Pressure Regulated Volume Control)	<ul style="list-style-type: none"> Set Mode to Vol. Targeted-PC Set Breath Rate Set Pres. Minimum and Pres. Adj. Rate Set Flow Trigger Set High Pressure Alarm 5 cmH₂O above desired maximum pressure 	<ul style="list-style-type: none"> Inspiratory Time Target Volume PEEP Pressure Control Flow Termination Flow Cycle Rise Time
SIMV-Pressure or PC-SIMV (Synchronized Intermittent Mandatory Ventilation) +/- Pressure Support	<ul style="list-style-type: none"> Set Mode to SIMV-Pressure Set Breath Rate Set Flow Trigger Set Pressure Control Set Pressure Support (measured above the set PEEP) 	<ul style="list-style-type: none"> Inspiratory Time PEEP Pressure Control Flow Termination Flow Cycle Time Cycle Rise Time
SIMV + PRVC (Synchronized Intermittent Mandatory Ventilation) + (Pressure Regulated Volume Control)	<ul style="list-style-type: none"> Set Mode to Vol. Targeted-SIMV Set Breath Rate Set Pres. Minimum and Pres. Adj. Rate Set Flow Trigger Set High Pressure Alarm 5 cmH₂O above desired maximum pressure 	<ul style="list-style-type: none"> PEEP Tidal Volume Pressure Support (measured above the set PEEP) Inspiratory Time Pressure Control Flow Termination Flow Cycle Time Cycle Rise Time

Comparable Non-Invasive Ventilation Modes

Ventilation Mode or Feature	Equivalent V*Home Mode Settings	Additional V*Home Controls
S/T (Spontaneous/Timed)	<ul style="list-style-type: none"> • Set Mode to Bi-Level • Set Breath Rate • Set Flow Trigger 	<ul style="list-style-type: none"> • Inspiratory Time • EPAP • IPAP (measured from a baseline of 0 cmH₂O) • Flow Cycle • Time Cycle • Rise Time
AVAPS™, PRVS (Average Volume Assured Pressure Support) (Pressure Regulated Volume Support)	<ul style="list-style-type: none"> • Set Mode to Vol. Targeted-PS • Set Breath Rate • Set Pres. Minimum and Pres. Adj. Rate • Set Flow Trigger • Set High Pressure Alarm 5 cmH₂O above desired maximum pressure 	<ul style="list-style-type: none"> • Inspiratory Time • PEEP • Tidal Volume • Flow Cycle • Time Cycle • Rise Time
T (Timed)	<ul style="list-style-type: none"> • Set Mode to AC-Pressure • Set Breath Rate • Set Flow Trigger to Off • Set Pressure Control Flow Termination to Off 	<ul style="list-style-type: none"> • Inspiratory Time • PEEP • Pressure Control (measured above the set PEEP) • Rise Time
Pressure Support S (Spontaneous)	<ul style="list-style-type: none"> • Set Mode to SIMV-Pressure or SIMV-Volume • Set Breath Rate to 0 • Set Pressure Support 	<ul style="list-style-type: none"> • Inspiratory Time (Apnea backup) • Pressure Control (Apnea backup if SIMV-Pressure) • Tidal Volume (Apnea backup if SIMV-Volume) • PEEP • Flow Cycle • Time Cycle • Rise Time • Apnea Rate
CPAP (Continuous Positive Airway Pressure)	<ul style="list-style-type: none"> • Set Mode to SIMV-Pressure or SIMV-Volume • Set Breath Rate to 0 • Set PEEP to desired CPAP level • Set Pressure Support to 0 	<ul style="list-style-type: none"> • Inspiratory Time (Apnea backup) • Pressure Control (Apnea backup if SIMV-Pressure) • Tidal Volume (Apnea backup if SIMV-Volume) • Flow Cycle • Time Cycle • Rise Time • Apnea Rate

The Touchscreen

Use the V*Home touchscreen to configure and operate the device, as well as monitor the patient. This chapter provides an overview of the information and controls available on each of the four main tabbed navigation screens.

NOTE: If V*Home controls become difficult to select, use the Calibrate Touchscreen control to recalibrate the touchscreen sensor. See *“Available Device Settings”* on page 79.

Locking the Touchscreen

To lock the V*Home touchscreen and protect against accidental button presses, press and hold the lock screen button in the status bar for three seconds. The icon will change to indicate the screen is locked, and a pop-up message will appear when the screen is touched.

To unlock the touchscreen, press and hold the lock screen icon in the status bar for 3 seconds again.



Quick View

The Quick View menu provides streamlined access to commonly used V*Home therapies and features. Use the small arrow near the manometer to expand the Quick View menu and select from up to four actions.

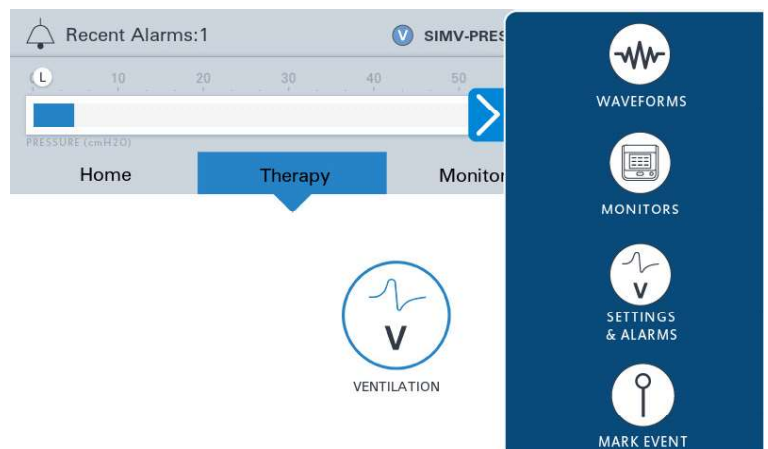

The Status Bar

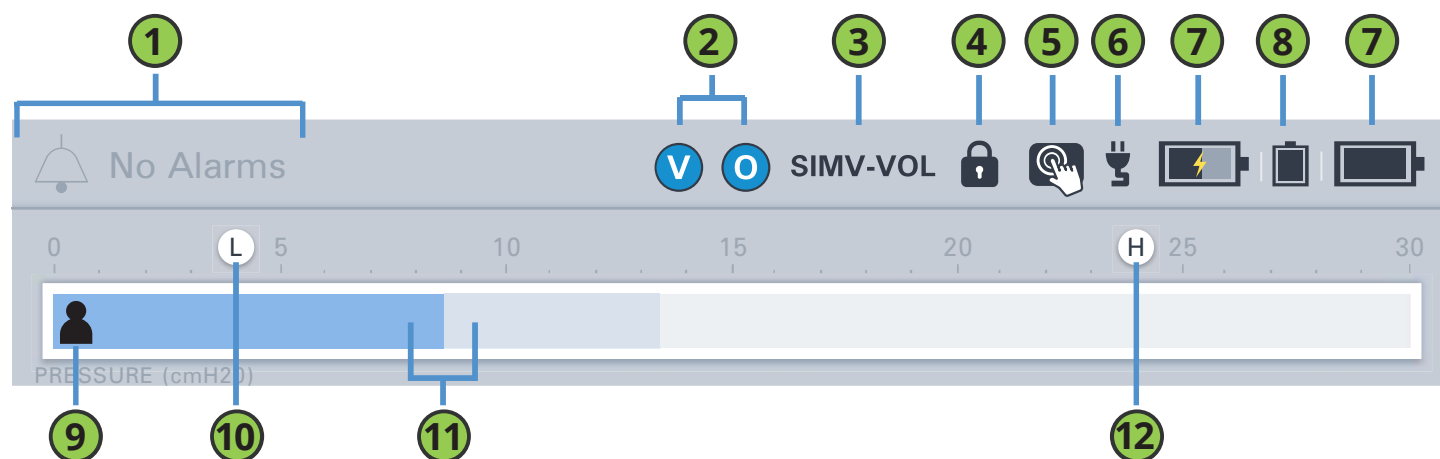

The status bar remains at the top of the screen during V*Home use. The status bar includes the following indicators:

Description	
1	Alarm indicator. If an alarm condition occurs, the name of the alarm will display, along with a visual (color) indicator of alarm severity. Press the alarm indicator at any time to access the V*Home Alarm and Event Logs. See <i>"The Alarm Log"</i> on page 91 and <i>"The Event Log"</i> on page 92 for more information.
2	Therapy indicator. The active therapy (Ventilation, Oxygen, and/or Nebulizer) will appear as an icon.
3	Ventilation Mode indicator. The active Ventilation Mode control setting displays as an abbreviation. See <i>"V*Home Ventilation Modes"</i> on page 39 for a description of each available mode.
4	Clinician Unlock indicator. When V*Home is in Clinician Unlock mode, an unlocked padlock appears on the top of the touchscreen. While V*Home is locked, a locked padlock is displayed.
5	Screen Lock button. Press and hold the icon for 3 seconds to lock or unlock the V*Home touchscreen. When locked, an orange "X" will appear in the icon, and the screen will be protected from accidental button presses.
6	External power indicator. A plug icon will appear and remain on the top of the screen when V*Home is connected to external power.
7	Removable battery indicators. Two battery icons indicate the charging status and remaining battery power of each of the two removable batteries. The icon on the left indicates the status of the battery installed in the left battery well. The icon on the right indicates the status of the battery installed in the right battery well. See <i>"Glossary of Indicators"</i> on page 139 for more information.
8	Internal battery indicator. A battery icon indicates the charging status and remaining battery power of the internal battery. If the icon fill is below 50% (turns yellow) or below 33% (turns red), find an external source of power immediately. See <i>"Glossary of Indicators"</i> on page 139 for more information.
9	Patient triggered indicator. This icon will appear if the current breath is triggered by patient effort to breathe.
10	Low Pressure alarm indicator. This icon marks the set Low Pressure alarm limit.
11	Pressure monitor. This pressure manometer will increase (to the right) and decrease (to the left) as breaths are delivered to the patient. The dark blue bar represents the pressure delivered during the current breath. The light blue bar represents the peak pressure delivered during the previous breath.
12	High Pressure alarm indicator. This icon marks the set High Pressure alarm limit.

The Home Screen

The Home screen displays three configurable monitors (for example, Breath Rate, Tidal Volume, and the active Ventilation therapy Preset).

The three monitors configured to display on the top row of the Monitors tab will appear on the Home screen.

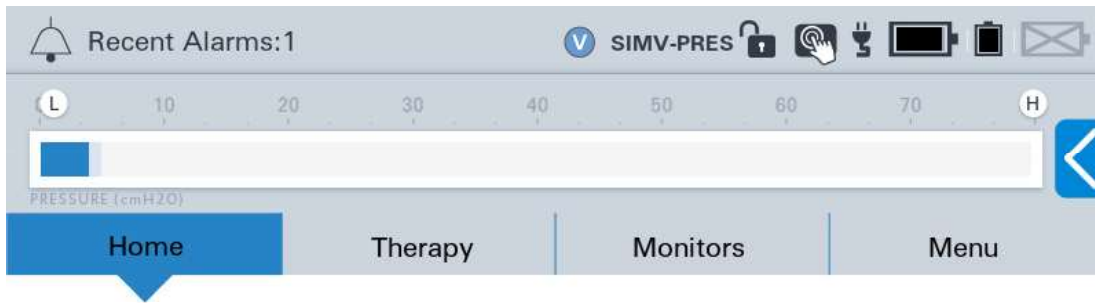

12 BPM
BREATH RATE

18 mL
ESTIMATED VTE

Preset 1
PRESET



Night Mode and Day Mode

Use the Home screen to change between Night Mode and Day Mode.

- 1** Press the **NIGHT MODE** button on the Home screen to dim the LCD display. The screen will remain dimmed while in use.
- 2** Press **DAY MODE** to restore full screen brightness.



The Therapy Screen

Use the Therapy screen to configure and start Ventilation, or to configure V*Home for use with external Oxygen and Nebulizer therapies.

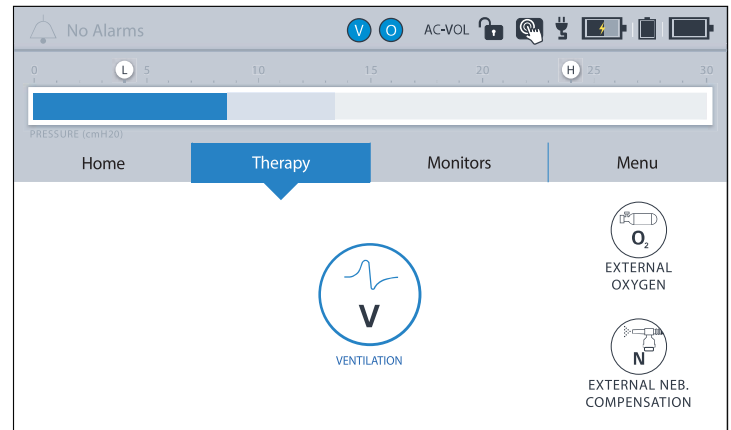

The Monitors Screen

The Monitors screen displays measured or calculated information about delivered Ventilation and Oxygen therapy. Use the **CUSTOMIZATION** button to choose which display on the screen.

To aid clinicians charting activities, an additional page of control settings is visible from the Monitors screen. Press the down arrow at the bottom of the Monitors screen to view currently active Ventilation and Oxygen therapy control settings. The controls listed on this page are configurable using the **CUSTOMIZATION** button.

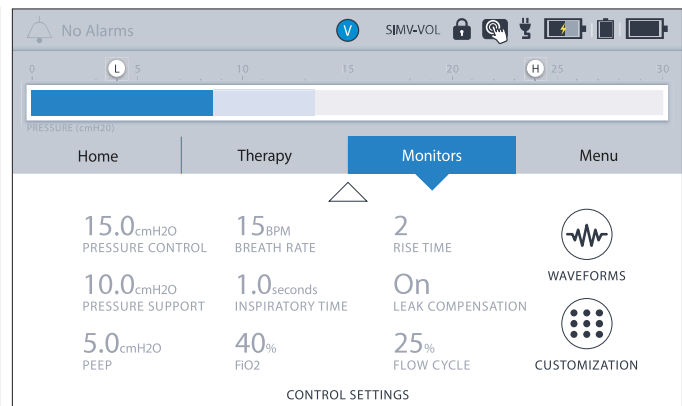
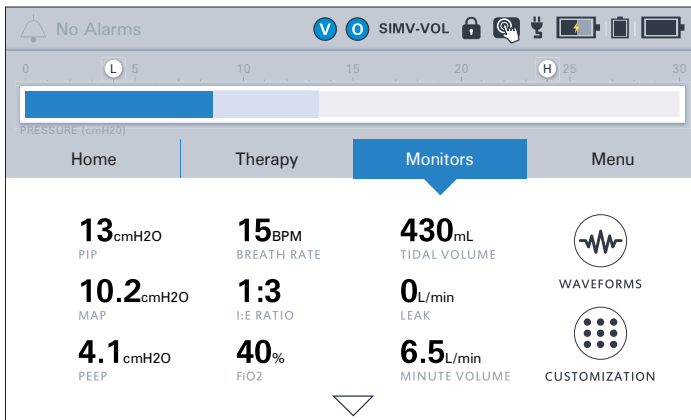

The Customization Button

The monitors and controls displayed on this screen are configurable. Press the **CUSTOMIZATION** button on each page to configure the layout and content of the Monitors screen.

The three monitors configured to display on the top row of the Monitors tab will appear on the Home screen. See *"Monitor Screen Customization" on page 97* for detailed instructions.



The Waveforms Button

Press the **WAVEFORMS** button on the right side of the screen to display the real-time flow, pressure, and volume waveforms delivered during Ventilation therapy. Two of these three waveforms will display at a time. These waveform displays can be scaled, paused, and resumed as appropriate for monitoring the patient.



The Menu Screen

The Menu screen provides access to additional system settings and features. This section includes a description of the information and controls accessible through each button on the Menu screen.

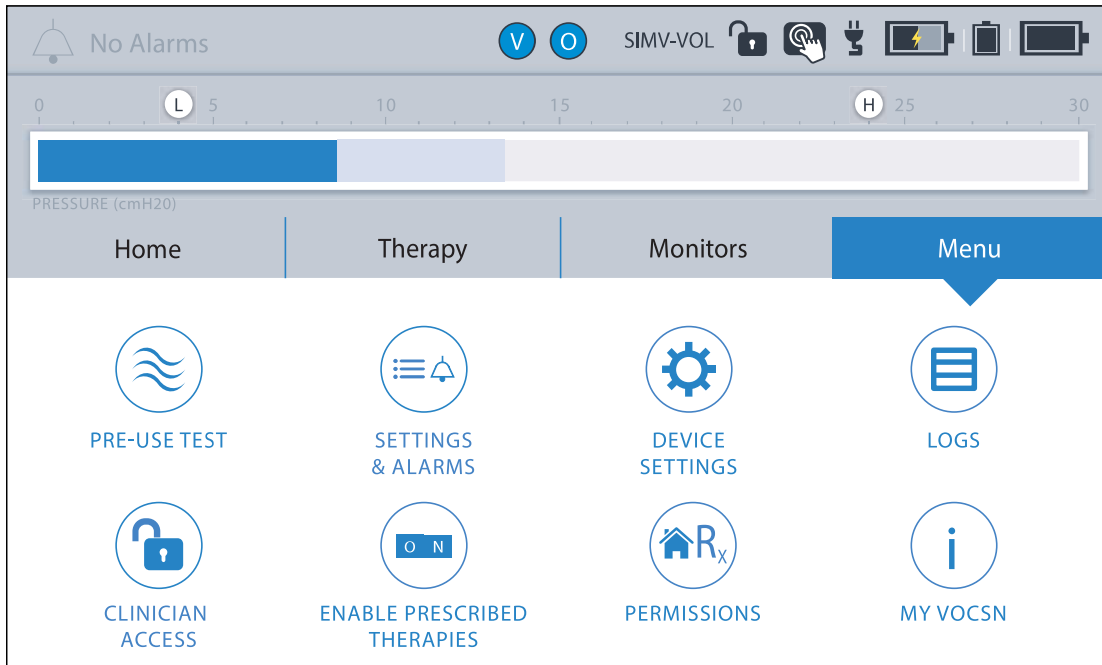

The Pre-Use Test Button

Press the **PRE-USE TEST** button to run a user-initiated Pre-Use Test. Perform a Pre-Use Test any time a Ventilation therapy control or the Ventec One-Circuit is modified, affecting the delivered Ventilation therapy.

See *“Running the Pre-Use Test”* on page 34 for more information.

NOTE: If Ventilation therapy is critical to patient care, provide the patient with backup ventilation prior to initiating the Pre-Use Test.



The Settings & Alarms Button

Press the **SETTINGS & ALARMS** button to modify Ventilation control settings and alarms for any of the three configured Ventilation therapy Presets. This button will open the Ventilation Presets configuration screen.

See *“Changing Ventilation Therapy Settings” on page 60* and *“Changing Alarm Settings” on page 81* for configuration instructions.



The Device Settings Button

Press the **DEVICE SETTINGS** button to modify V*Home system controls such as alarm volume.

See *“Device Settings” on page 78* for more information.



The Logs Button

Press the **LOGS** button to view the Alarm Log and the Event Log. The V*Home Logs screen is also accessible by tapping the alarm icon in the status bar.

See *“The Alarm Log” on page 91* and *“The Event Log” on page 92* for more information.



The Clinician Access Button

When the **Unlock Required?** device setting is set to **Yes**, pressing the **CLINICIAN ACCESS** button locks and unlocks V*Home. See *“Clinician Access Mode” on page 76* for more information.

Pressing the padlock button will prompt you to enter a Clinician Access Passcode to unlock the device and allow the configuration of all control settings.



Each V*Home has a unique Clinician Access passcode. The passcode is the last four digits of the device serial number. This number is printed on the V*Home back label. It is also visible from the Service section of the **MY VOCSN** screen.

When V*Home is unlocked, pressing the unlocked padlock button will lock the device again. V*Home will also automatically lock again after 15 minutes, regardless of user interaction with the device.

NOTE: Only controls set to “User and Clinician” in the Permissions screen will remain configurable when V*Home is locked.

The Enable Prescribed Therapies Button

Press the **ENABLE PRESCRIBED THERAPIES** button to enable or disable the FiO2 Monitor.

See *“Enabling and Disabling Prescribed Therapies” on page 72* for more information.

NOTE: The Enable Prescribed Therapies menu button is only available when V*Home is in Clinician Access mode. See *“Enabling and Disabling Prescribed Therapies” on page 72* for instructions.



The Permissions Button

Press the **PERMISSIONS** button to set which controls are configurable when the device is locked. Controls set to “Clinician Only” will not be configurable until a Clinician Access Passcode is entered. Controls set to “User and Clinician” will be configurable at all times.

See *“Configuring Permissions” on page 77* for more information.

NOTE: The Permissions menu button is only available when V*Home is in Clinician Access mode. See *“Entering the Clinician Access Passcode” on page 76* for instructions.



The My VOCSN Button

Press the **MY VOCSN** button in the menu for system information including the device configuration, serial number, and installed software version.



Controls and Settings

V*Home controls are used to configure how the device behaves and delivers therapy. This chapter describes each of the V*Home controls, lists the available settings, and provides configuration instructions.

After configuring a control, press **ACCEPT** to confirm and activate your selection. While modifying Ventilation settings, controls will operate normally at the last confirmed setting until you press the **ACCEPT** button to confirm the change.

WARNING: To ensure patient safety, check the Ventec One-Circuit and verify that all system settings and Presets are appropriate before providing therapy, and on a routine basis during therapy.

NOTE: If the V*Home Permissions are configured for Clinician Only access to controls, those controls will be unavailable until entry of the Clinician Access password. See "*Clinician Access Mode*" on page 76 for more information.

NOTE: Control settings are not affected by system power interruption.

NOTE: V*Home devices come with pre-configured initial settings to aid in rapid emergency response. These settings are present when using the device for the first time. Using the Reset Settings for New Patient control will reset all controls to the default settings described in this chapter (not those that came pre-installed on the unit.)

The sections that follow provide configuration instructions, and list the adjustable control settings available on V*Home.

Ventilation Therapy Controls

V*Home stores up to three pre-configured Ventilation therapy Presets. These Presets can be enabled and configured using the **SETTINGS & ALARMS** button on the Ventilation screen or Menu screen.

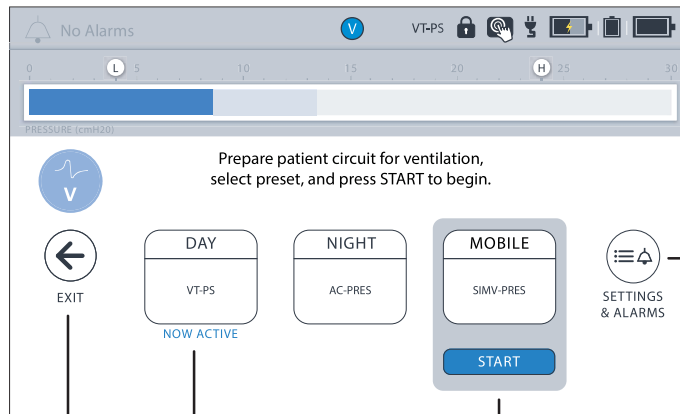

Press here if you need to change a control

Changing Ventilation Therapy Settings

To configure the Ventilation therapy Presets:

- 1 Press the **Therapy** tab under the status bar, and then press the **VENTILATION** therapy button.
- 2 Press the **SETTINGS & ALARMS** button on the right side of the screen. The Ventilation therapy Preset configuration screen will appear. To modify any of the three Ventilation therapy Presets, select the relevant Preset name from the tabs at the top of the configuration screen.



Press here to EXIT this screen

This preset is providing therapy

To start using a new preset, select it and then press START

NOTE: To enable a disabled Ventilation therapy Preset, press the Preset name, and then the **[Preset Name] Enable** control. Press **EDIT >**, and then select **Enabled**, and press **ACCEPT**.

- 3 Scroll through the list of available Ventilation controls, and press the name of the control requiring configuration. Press the **EDIT >** button on the right side of the screen.
- 4 Enter the new control setting using the numeric keypad, the slider bar, or the +/- buttons.
- 5 Press **ACCEPT** to activate your selection.
- 6 Follow the procedure above to modify additional controls. When configuration is complete, press the **< EXIT** tab.

NOTE: To configure V*Home alarms, scroll past the ventilation controls until you see the **ALARMS** banner. Alarm controls are listed below the banner. See *"Changing Alarm Settings"* on page 81 for configuration instructions.

Available Ventilation Therapy Settings

The following table lists the configurable Ventilation therapy controls available on V*Home. These controls are available separately for each of the three configurable Ventilation therapy Presets.

NOTE: Controls that cannot be edited will appear in gray. Controls may be locked because of the Permissions and Clinician Unlock feature. In addition, the Mode and Circuit Type controls will appear in gray and cannot be edited while the selected Ventilation Preset is running. These three controls can only be modified in an inactive Preset.

NOTE: The resolution of each control with numerical settings is 1, unless otherwise stated in the control description.

NOTE: **Black** text indicates the default setting.

Ventilator Control	Settings	Description
Apnea Rate	4 to 60 BPM Backup 12 BPM Backup	The Apnea Rate control sets the breath rate at which mandatory breaths will be delivered to the patient while the Apnea alarm is activated. NOTE: The Apnea Rate control is not available when Circuit Type is set to Mouthpiece.
Breath Rate	0 to 60 BPM 12 BPM	The Breath Rate control configures the minimum number of breaths per minute (BPM) delivered to the patient.

Ventilator Control	Settings	Description
Circuit Type	Passive, Mouthpiece, Valveless	<p>Set the Circuit Type control to correspond with the type of patient circuit used during Ventilation therapy.</p> <p>NOTE: The Circuit Type control cannot be modified for the running Ventilation therapy Preset. To modify the Circuit Type control, select an inactive ventilation Preset, set the Circuit Type control (and all other relevant controls) as desired, and then activate the Preset.</p> <p>NOTE: For more information on setting V*Home controls for Mouthpiece ventilation, see <i>"Setting V*Home Controls for Mouthpiece Ventilation"</i> on page 71.</p>
EPAP	Passive circuit: 4 to 25 cmH2O 5 cmH2O	<p>Expiratory Positive Airway Pressure. The set EPAP will determine the pressure maintained between breaths and during the expiratory phase of breaths when the Ventilation Mode is set to Bi-Level.</p>
Flow	15 to 60 L/min when the Patient Type control is set to Adult 30 L/min 4 to 25 L/min when the Patient Type control is set to Pediatric	<p>During High Flow therapy, the Flow control is used to set the rate of gas flow in L/min through a high flow nasal cannula or other interface.</p> <p>NOTE: The Flow control is only available when the High Flow control is set to On.</p> <p>PRECAUTION: V*Home Nebulizer therapy is not recommended during High Flow therapy for pediatric patients receiving <11 L/min. At Flow settings of <11 L/min, the accuracy of the delivered flow may be affected by Nebulizer therapy.</p> <p>Because the minimum flow from V*Home is 5 L/min during High Flow with software versions 5.00 and later, and Nebulizer therapy adds additional flow to the patient circuit (typically 6 L/min when used as directed), the minimum flow to the patient will be 11 L/min, and the displayed flow value may not accurately represent the actual flow delivered.</p>

Ventilator Control	Settings	Description
Flow Cycle	10 to 90% 25%	<p>Spontaneous breaths will cycle at the set Flow Cycle percentage of peak inspiratory flow. Setting the Flow Cycle control to 90% will result in a shorter inspiratory time; setting the Flow Cycle control to 10% will result in a longer one.</p> <p>When PC Flow Termination is set to On, mandatory and assist pressure breaths will cycle at the set Inspiratory Time or the set Flow Cycle percentage of the peak inspiratory flow, whichever comes first.</p> <p>NOTE: The Flow Cycle control is adjustable in increments of 5%.</p>
Flow Trigger	Active or Passive circuit: 0.5 to 9.0 L/min, Off Mouthpiece circuit: 0.5 to 3.0 L/min 2.0 L/min	<p>The set Flow Trigger will determine the flow differential necessary to initiate patient-triggered assist and spontaneous breaths.</p> <p>NOTE: The Flow Trigger control is adjustable in increments of 0.5.</p>
High Flow (available on English configurations with Leak+ compatible hardware, and Japanese configurations)	On, Off	<p>High Flow therapy provides a continuous flow of gas through a high flow nasal cannula or other interface. Set this control to On to access the Flow control.</p> <p>The High Flow control is available on Leak+ compatible devices when the Mode control is set to SIMV-Pressure, SIMV-Volume, or Vol. Targeted-SIMV. Like the CPAP function in SIMV modes, during High Flow therapy there is no set Breath Rate and all breaths are spontaneous.</p> <p>NOTE: To ensure proper performance of the Pre-Use Test, set the Circuit Type control to Valveless before setting High Flow to On. (Software versions 5.00 and later will automatically set the Circuit Type to Valveless when enabling High Flow.)</p> <p>NOTE: For more information about the availability of the VOCSN Leak+ feature (including High Flow therapy), see <i>"Leak+ Performance"</i> on page 11.</p>
High Pressure Delay	None, 1 Breath, 2 Breaths	<p>High Inspiratory Pressure Alarm Delay. When enabled (1 Breath or 2 Breaths), the auditory and visual indicators for the High Pressure alarm will not activate until after the set number of consecutive breaths have exceeded the High Pressure alarm setting.</p> <p>NOTE: The (H) indicator in the status bar will flash red, and VOCSN will limit the pressure of the Ventec One-Circuit every time the High Pressure alarm setting is exceeded, regardless of the High Pressure Delay setting.</p>

Ventilator Control	Settings	Description
Humidification	Humidifier, HME	<p>Set the Humidification control to correspond to the type of humidification used during Ventilation therapy.</p> <p>NOTE: Based on the set Patient Type and Humidification Type, VOCSN automatically adjusts delivered therapy to compensate for differences in the compliance and volume of the Ventec One-Circuit.</p> <p>NOTE: When used with active, passive, and valveless Ventec One-Circuits, VOCSN was designed for use with a humidifier or HME. If used with neither, set the Humidification control to HME.</p>
Inspiratory Time	0.3 to 5.0 seconds 1.0 second	<p>The Inspiratory Time control configures the duration over which the set pressure or volume is delivered to the patient during the inspiratory phase of each mandatory or assist breath.</p> <p>NOTE: The resolution of the Inspiratory Time control is 0.1 seconds.</p>
IPAP	4 to 40 cmH ₂ O above ambient 10 cmH₂O above ambient	<p>Inspiratory Positive Airway Pressure. The set IPAP will determine the pressure delivered during the inspiratory phase of mandatory and spontaneous breaths when the Ventilation Mode is set to Bi-Level or Spontaneous.</p>
Mode	Bi-Level, Spontaneous, Assist/Control-Pressure, SIMV-Pressure, Assist/Control-Volume, SIMV-Volume Vol. Targeted-PS Vol. Targeted-PC Vol. Targeted-SIMV	<p>The set ventilation Mode determines how breaths are delivered to the patient. See <i>"Breath Types"</i> on page 36 for a description of how breaths are delivered in each available mode.</p> <p>NOTE: The Mode control cannot be modified for the active Ventilation therapy Preset. To modify the Mode control, select an inactive ventilation Preset, set the Mode control (and all other relevant controls) as desired, and then activate the Preset.</p>
Patient Type	Adult , Pediatric	<p>Set the Patient Type control to correspond to the type of Ventec One-Circuit (adult or pediatric) used during Ventilation therapy.</p> <p>NOTE: Based on the set Patient Type and Humidification Type, VOCSN automatically adjusts delivered therapy to compensate for differences in the compliance and volume of the Ventec One-Circuit.</p> <p>NOTE: Because of the circuit diameter, set the Patient Type control to Pediatric whenever the Circuit Type control is set to Mouthpiece.</p>

Ventilator Control	Settings	Description
PC Flow Termination	Off, On	Pressure Control Flow Termination. When the PC Flow Termination Control is set to On, mandatory and assist pressure breaths will cycle if the set Flow Cycle percentage of the peak inspiratory flow is reached, if the set Inspiratory Time has not yet elapsed.
PEEP	Active circuit: 0 to 25 cmH ₂ O Passive or Valveless circuit: 4 to 25 cmH ₂ O 5 cmH ₂ O	Positive End-Expiratory Pressure. The set PEEP will determine the pressure maintained between breaths and during the expiratory phase of breaths. NOTE: When the Circuit Type control is set to Mouthpiece, the PEEP control is disabled.
Preset [1, 2, 3] Enable	Disabled, Enabled Preset 1: Enabled Preset 2 and 3: Disabled	The Preset [1, 2, or 3] Enable control enables or disables the configuration and use of any of the three configurable Ventilation therapy Presets.
Preset [1, 2, 3] Label	Preset 1, Preset 2, Preset 3	Use the [Preset Name] Label control to rename any of the three configurable Ventilation therapy Presets. Each Preset can be renamed using up to 10 alphanumeric characters.
Pres. Adj. Rate	Slow, Fast	In Volume Targeted ventilation modes, the Pres. Adj. Rate control determines the rate of pressure adjustments made to achieve the set Tidal Volume. Setting the Pres. Adj. Rate control to Slow will increment breaths by up to ± 1 cmH ₂ O per breath. The fast setting will increment breaths by up to ± 3 cmH ₂ O per breath. For more information, see <i>"Volume Targeted Ventilation Overview" on page 44.</i>
Pres. Minimum	1 to [40-PEEP] cmH ₂ O 5 cmH ₂ O	In Volume Targeted ventilation modes, the Pres. Minimum setting determines the minimum pressure of all Volume Targeted breaths. For more information, see <i>"Volume Targeted Ventilation Overview" on page 44.</i> NOTE: The Pres. Minimum setting may cause VOCSN to deliver more volume than intended by the Tidal Volume setting. Ventec Life Systems recommends using the High Minute Volume alarm to detect this condition.
Pressure Control	1 to [50-PEEP] cmH ₂ O above PEEP 10 cmH ₂ O above PEEP	The set Pressure Control will determine the pressure above PEEP delivered during mandatory and assist breaths when the Ventilation Mode is set to Assist/Control-Pressure or SIMV-Pressure.

Ventilator Control	Settings	Description
Pressure Support	0 to [40-PEEP] cmH ₂ O above PEEP 10 cmH₂O above PEEP	The set Pressure Support will determine the pressure above PEEP delivered during the inspiratory phase of spontaneous breaths during SIMV ventilation modes.
Rise Time	1 to 6 4	<p>The Rise Time setting adjusts the speed of pressure elevation for pressure breaths. Lower settings (such as 1) raise the pressure quickly. Higher settings (such as 6) will slow the rate of pressure elevation.</p> <p>A high Rise Time setting in conjunction with a low Inspiratory Time setting may result in a lower peak inspiratory setting than expected. Adjust the Rise Time control as needed to both maximize patient comfort, and ensure that the target peak inspiratory pressure is reached.</p>
Sigh	Off, On	<p>When the Sigh control is set to On, a volume mandatory or assist breath is delivered at 150% the set Tidal Volume every 100th mandatory or assist breath.</p> <p>NOTE: The Sigh control is only available in volume Ventilation Modes (Assist/Control-Volume and SIMV-Volume).</p>
Tidal Volume	50 to 1500 mL 500 mL	<p>The Tidal Volume control adjusts the volume delivered to the patient during the inspiratory phase of volume breaths, or of pressure breaths when in Volume Targeted ventilation modes.</p> <p>NOTE: The resolution of the Tidal Volume control is 5 mL.</p> <p>NOTE: When delivering a Tidal Volume between 250 and 300 mL, an adult or pediatric Ventec One-Circuit may be used. Tidal Volumes ≥ 250 mL are typically appropriate for an adult Ventec One-Circuit. Tidal Volumes ≤ 300 are typically appropriate for a pediatric Ventec One-Circuit. Follow your healthcare institution's protocol for Ventec One-Circuit use and Tidal Volume delivery.</p> <p>NOTE: PEEP settings of 3 cmH₂O or less may reduce the accuracy of Tidal Volumes of 50 to 70 mL. For the best VOCSN performance, set PEEP to 4 cmH₂O or greater when the set Tidal Volume is 50 to 70 mL.</p>
Time Cycle	0.3 to 3.0 seconds 1.5 seconds	<p>Spontaneous breaths will cycle if the set Time Cycle has elapsed without the set Flow Cycle causing a breath to cycle.</p> <p>NOTE: The resolution of the Time Cycle control is 0.1.</p>

Control Limiting

V*Home restricts the availability of some control settings when the set value of another interdependent control creates a limit. For example, available PEEP and Pressure Control settings are interdependent and control limited. If the PEEP control is set to 25 cmH₂O, the available Pressure Control settings are automatically limited to 25 cmH₂O or less to prevent VOCSN from delivering a total maximum pressure exceeding 50 cmH₂O.

If a limit is reached during control configuration, V*Home will display a message on the configuration screen, indicating which interdependent control is limiting available settings. To adjust the setting of a control beyond its control limit, the interdependent control setting must be changed first.

The table below lists controls that are interdependent and control-limited, and describes the reason for the limit

Controls	Control limited to ensure:
Breath Rate (including Apnea Rate) and Inspiratory Time	The maximum inspiratory time will not exceed 0.5, multiplied by 60, divided by the set Breath Rate (or Apnea Rate). This is to prevent inverse I:E ratios.
EPAP and IPAP	The set IPAP is greater than the set EPAP, and the total delivered pressure will not exceed 40 cmH ₂ O.
High Pressure alarm and Pressure Control or Pressure Support	The High Pressure alarm is not set less than 3 cmH ₂ O above the set Pressure Control or Pressure Support.
Mode and Circuit Type controls for the active Ventilation Preset	Controls are configured at intended settings before beginning therapy.
PEEP and Pressure Support	The total delivered pressure will not exceed 40 cmH ₂ O.
PEEP and Pressure Control	The total delivered pressure will not exceed 50 cmH ₂ O.
Pres. Minimum, PEEP, and High Pressure alarm	To ensure the minimum pressure of breaths is less than the maximum pressure of breaths during Volume Targeted ventilation.
Tidal Volume and Inspiratory Time	Volume breaths will not deliver a flow greater than 120 L/min, or less than 10 L/min.

Controls Available in Each Ventilation Mode

The table below lists the controls available for configuration depending on the set Ventilation Mode. Unavailable controls will not be visible when setting Ventilation therapy controls.

NOTE: Controls available regardless of the set Ventilation Mode are not listed in the following table.

Control	Bi-Level	Spontaneous	Assist/ Control- Pressure	SIMV- Pressure	Assist/ Control- Volume	SIMV- Volume	Vol, Targeted- PS	Vol-Targeted- PC	Vol. Targeted- SIMV	High Flow	
Apnea Rate	Yes, when Circuit Type is set to Passive or Valveless	No			Yes, when Circuit Type is set to Passive or Valveless						No
Breath Rate	No	No	Yes, when Circuit Type is set to Passive or Valveless	Yes	Yes, when Circuit Type is set to Passive or Valveless	Yes	No	Yes, when Circuit Type is set to Passive or Valveless	Yes	No	
EPAP	Yes	No	No	No	No	No	No	No	No	No	
Flow	No	No	No	Yes, when High Flow is set to On	No	Yes, when High Flow is set to On	No	No	Yes, when High Flow is set to On	Yes	
Flow Cycle	Yes	Yes	Yes, when PC Flow Termination is set to On	Yes	No	Yes	Yes	Yes, when PC Flow Termination is set to On	Yes	No	

Control	Bi-Level	Spontaneous	Assist/ Control- Pressure	SIMV- Pressure	Assist/ Control- Volume	SIMV- Volume	Vol, Targeted- PS	Vol-Targeted- PC	Vol. Targeted- SIMV	High Flow	
High Flow	No	No	No	Yes,if device has Leak+ hardware	No	Yes, if device has Leak+ hardware	No	No	Yes, if device has Leak+ hardware	Yes, if device has Leak+ hardware, or is a Japanese configuration	
Insp Hold	No	No	No	No	Yes	Yes	No	No	No	No	
Inspiratory Time	Yes	No	Yes	Yes	Yes	Yes	Yes	Yes	Yes	No	
IPAP	Yes	Yes	No	No	No	No	No	No	No	No	
Leak Compensation	NOTE: The Leak Compensation control is always On when the Circuit Type control is set to Passive or Valveless, and always Off when the Circuit Type control is set to Mouthpiece.										
PC Flow Termination	No	No	Yes	Yes	No	No	No	Yes	Yes	No	
PEEP	No	No	Yes, when Circuit Type is set to Passive or Valveless								No
Pres. Adj. Rate	No	No	No	No	No	No	Yes	Yes	Yes	No	
Pres. Minimum	No	No	No	No	No	No	Yes	Yes	Yes	No	
Pressure Control	No	No	Yes	Yes	No	No	No	No	No	No	

Control	Bi-Level	Spontaneous	Assist/ Control- Pressure	SIMV- Pressure	Assist/ Control- Volume	SIMV- Volume	Vol, Targeted- PS	Vol-Targeted- PC	Vol. Targeted- SIMV	High Flow
Pressure Support	No	No	No	Yes	No	Yes	No	No	Yes	No
Rise Time	Yes	Yes	Yes	Yes	No	Yes	Yes	Yes	Yes	No
Sigh	No	No	No	No	Yes	Yes	No	No	No	No
Tidal Volume	No	No	No	No	Yes	Yes	Yes	Yes	Yes	No
Time Cycle	Yes	Yes	No	Yes	No	Yes	Yes	No	Yes	No

Setting V*Home Controls for Mouthpiece Ventilation

Mouthpiece patient circuits are intended for use with patients at least 5 years of age, who can place their mouths on the circuit to initiate breaths on their own.

NOTE: Because of the circuit size, set the Patient Type control to Pediatric during mouthpiece ventilation, even when VOCSN is used with an adult patient. For more information on mouthpiece circuit configuration, see *"Mouthpiece Patient Circuit Setup"* on page 30.

Setting the Circuit Type control to Mouthpiece will limit the available V*Home ventilation modes, controls, monitors, and alarms as follows:

- The ventilation Mode control is limited to Spontaneous, Assist/Control-Pressure, and Assist/Control Volume. In Assist/Control ventilation modes, only assist breaths will be provided to the patient.
- The Breath Rate, Apnea Rate, PEEP, and Leak Compensation controls are unavailable.
- The Flow Trigger control is limited to 1 to 3 L/min
- The Patient Circuit Disconnect, Low Minute Volume, and High Minute Volume alarms are unavailable.
- The Exhaled Tidal Volume, Minute Volume, and Leak monitors are unavailable.
- The Humidification control is unavailable, because humidification is not used with mouthpiece patient circuits.

NOTE: In some cases, setting the High Pressure or Apnea alarm and using the Breath Rate monitor may help ensure patient safety.

Setting V*Home Controls for High Flow Therapy

High Flow therapy is intended for use with spontaneously breathing patients, and is most often delivered through a high flow nasal cannula.

NOTE: For more information on using High Flow therapy with a nasal cannula, see *"Using a High Flow Nasal Cannula"* on page 22.

The High Flow control is available in SIMV ventilation modes. Setting the High Flow control to On will limit the available V*Home controls, so that only the Flow control is configurable, and only the Flow monitor displays a value. In addition, the available Ventilation therapy alarms will be limited to Patient Circuit Disconnect.

NOTE: To ensure proper performance of the Pre-Use Test, set the Circuit Type control to Valveless before setting High Flow to On.

Enabling and Disabling Prescribed Therapies

To use the FiO2 Monitor, ensure the relevant system control to **Enabled**. This features cannot be configured or activated until they are enabled.

To enable or disable an available V*Home therapy:

- 1** Press the **Menu** tab.
- 2** Press the **ENABLE PRESCRIBED THERAPIES** button.
- 3** Press the name of the applicable therapy.
- 4** Press **EDIT >** on the right side of the screen.
- 5** Select the new setting.
- 6** Press **ACCEPT** to activate your selection.
- 7** Follow the procedure above to modify additional controls. When configuration is complete, press the **< EXIT** tab.



The following controls and settings are available from the **ENABLE PRESCRIBED THERAPIES** Menu button.

NOTE: **Black** text indicates the default setting.

Therapy	Settings	Description
FiO2 Monitor	Disabled, Enabled	The FiO2 Monitor option enables or disables the use of VOCSN internal FiO2 monitor. NOTE: The FiO2 monitor is active only when the Oxygen Delivery Mode control is set to FiO2. See "Oxygen Controls" on page 73 for more information.

Oxygen Controls

Oxygen may be provided using the V*Home low-pressure oxygen port. See “*Oxygen Therapy Setup*” on page 31 for oxygen source setup instructions.

NOTE: The flow of oxygen from a low-pressure source is controlled by the source, not by the V*Home oxygen controls. Oxygen from a low-pressure oxygen source is additive, and can be used in conjunction with oxygen from an external source. See “*Connecting External Low-Pressure Oxygen*” on page 32 for more information.

Changing Oxygen Settings

V*Home can store up to three configured Oxygen therapy Presets. These Presets can be enabled and configured using the [SETTINGS & ALARMS](#) button on the Oxygen screen.

To change oxygen controls for any of the three Oxygen therapy Presets:

- 1 Press the [Therapy](#) tab, and then the [OXYGEN](#) button.
- 2 Select the Preset you want to modify, and then press the [SETTINGS & ALARMS](#) button on the right side of the screen. The Oxygen therapy Preset configuration screen will appear. You may select and configure any of the three Oxygen therapy Presets.

NOTE: To enable a disabled Oxygen therapy Preset, press the applicable Preset tab at the top of the settings screen, and then the [\[Preset Name\] Enable](#) control. Press [EDIT >](#), and then select [Enabled](#), and press [ACCEPT](#).

- 3 Select any of the available Oxygen controls. Press the [EDIT >](#) button on the right side of the screen.
- 4 Enter the new control setting by selecting it from the list, using the numeric keypad, the slider bar, or the +/- buttons.
- 5 Press [ACCEPT](#) to activate your selection.
- 6 Follow the procedure above to modify additional controls. When configuration is complete, press the [< EXIT](#) tab.

Available Oxygen Settings

The following Oxygen therapy settings are available on V*Home devices with the oxygen option enabled. Controls listed in this section are ordered as they appear in the V*Home user interface.

NOTE: **Black** text indicates the default setting.

Oxygen Control	Settings	Description
Preset [1, 2, 3] Enable	Disabled, Enabled	The Preset [1, 2, or 3] Enable control enables or disables the configuration and use of any of or all of the three configurable Oxygen therapy Presets.
Preset [1, 2, 3] Label	[up to 10 alphanumeric characters]	Use the Preset [1, 2, or 3] Label control to rename any of the three configurable Oxygen Presets. Each Preset can be renamed using up to 10 alphanumeric characters.
Oxygen Delivery Mode	O2 Bleed In	The O2 Bleed In setting is automatically displayed when Oxygen Source is set to Low Pressure O2 (see above).

Changing Nebulizer Compensation Settings

Nebulizer therapy can be configured to compensate for the flow added to the patient circuit from an external nebulizer. The Nebulizer Duration control may be set for a period of time between 5 and 60 minutes. To run Nebulizer therapy, first set the Nebulizer Duration control:

- 1 Press the **Therapy** tab, and then press the **NEBULIZER** button.
- 2 Press the plus (+) and minus (-) buttons on the right side of the screen to configure the Nebulizer Duration.
- 3 While Nebulizer therapy is running, you may use the plus (+) button to add more time if needed.
- 4 Press the **EXIT** button to return to the main menu. The next time you access the Nebulizer therapy screen, the Nebulizer Duration setting will remain at whatever it was last set to.

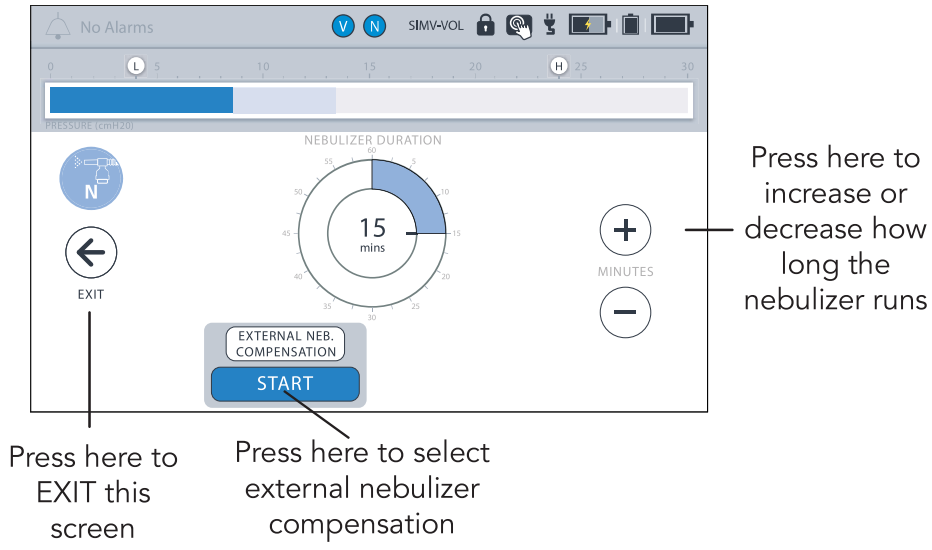

The following Nebulizer therapy control is available on V*Home.

NOTE: **Black** text indicates the default setting.

Nebulizer Control	Settings	Description
Nebulizer Duration	5 to 60 minutes 6 minutes	The Nebulizer Duration control sets the duration over which V*Home drives a connected nebulizer, or compensates for the flow from an external one. The resolution of the Nebulizer Duration control is 1 minute.

Clinician Access Mode

When the [Unlock Required?](#) device setting is set to [Yes](#), pressing the [CLINICIAN ACCESS](#) button locks and unlocks V*Home. Using the Permissions feature, V*Home can be configured to restrict which controls are configurable by all users, and which control settings can only be changed by first entering a Clinician Access Passcode to unlock V*Home.



When V*Home is unlocked, all therapies and device settings are configurable. Unlocking V*Home using the Clinician Access Passcode also allows access to the Permissions feature, where each control can be set to allow only clinician access (by first using the passcode), or set to allow configuration by all users at all times. See *"Configuring Permissions"* on page 77 for more information.

Once the Clinician Access Passcode is entered, V*Home will remain unlocked for 15 minutes. V*Home will automatically lock again after 15 minutes, regardless of user interaction with the device. V*Home can also be locked again at any time by pressing the Clinician Access button in the Menu tab.

Entering the Clinician Access Passcode

To enter the Clinician Access Passcode and unlock V*Home:

- 1** Press the [Menu](#) tab.
- 2** Press the [CLINICIAN ACCESS](#) button.
- 3** Enter the four-digit Clinician Access Passcode. The Clinician Access Passcode is the last four digits of the device serial number. This number is printed on the V*Home back label, and is also visible from the MY VOCSN screen.
- 4** Press [OK](#). V*Home will unlock, allowing the configuration of all therapy controls, permissions, and device settings.

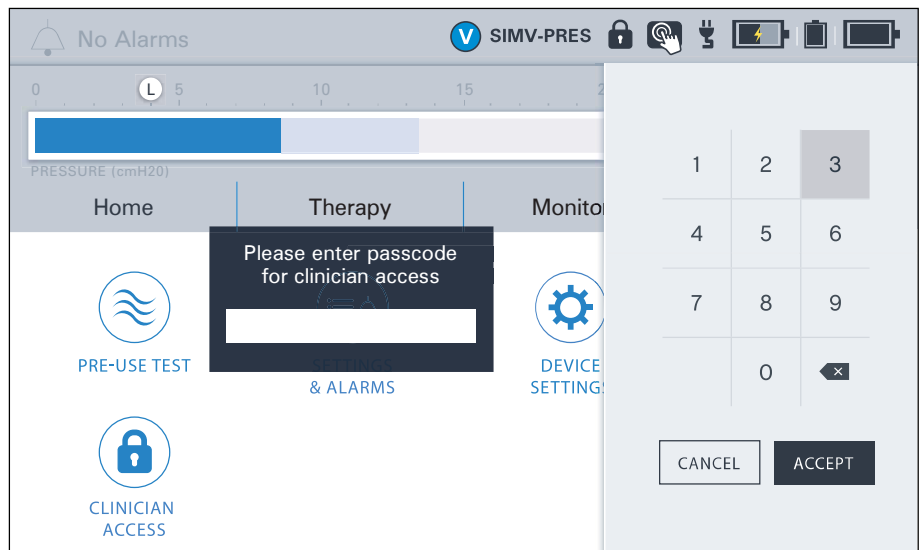

NOTE: When the [Unlock Required?](#) device setting is set to [Yes](#), V*Home will automatically lock after 15 minutes. To lock V*Home manually, press the [CLINICIAN ACCESS](#) button on the Menu screen.

Configuring Permissions

The Permissions feature allows clinicians to configure which V*Home controls are locked (cannot be changed) until the device is unlocked using the Clinician Access Passcode.

Control permissions set to User and Clinician are configurable at all times; they can be changed by anyone interacting with V*Home. When a control permission is set to Clinician Only, the control will remain locked until the Clinician Access Passcode is entered.

NOTE: Locked control settings will display in the configuration screen in gray.

To change control permissions:

- 1** If not already unlocked, enter the Clinician Access mode by following the procedure in *"Entering the Clinician Access Passcode"* on page 76.
- 2** Press the **PERMISSIONS** button on the **Menu** screen.
- 3** Select the appropriate tab and scroll to the control you want to lock or unlock. Slide the toggle to switch between **User and Clinician** and **Clinician Only** access to the selected control.
- 4** When Permissions configuration is complete, press the **< EXIT** tab near the top of the screen.

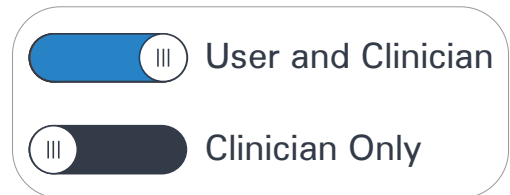

Device Settings

V*Home device settings are modifiable, and include controls such as Alarm Volume, whether Clinician Access mode is enabled on the device, and the displayed date and time.

Changing Device Settings

To change a device setting:

- 1 Press the **Menu** tab.
- 2 Press the **DEVICE SETTINGS** button.
- 3 Scroll to the applicable device setting and press its name.
- 4 Press **EDIT >** on the right side of the screen.
- 5 Enter the new control setting.
- 6 Press **ACCEPT** to save your selection.
- 7 Follow the procedure above to modify additional controls. When configuration is complete, press the **< EXIT** tab.



Available Device Settings

The following table lists the configurable device settings available on V*Home.

NOTE: If the internal battery depletes fully, V*Home Date and Time settings will reset to their default values. To ensure the Alarm and Event logs record information accurately, verify the V*Home Date and Time settings before use, and set them to the correct values if necessary.

NOTE: **Black** text indicates the default setting.

System Control	Settings	Description
Activate Battery Storage Mode	N/A	With software versions 4.11R and later, use the Activate Battery Storage Mode to place the fully charged internal battery and both removable, rechargeable batteries into a power-saving storage mode. This will preserve the battery charge and allow V*Home to remain in storage for 12 months between recharge intervals. See <i>"Battery Storage Mode"</i> on page 133 for instructions and more information.
Alarm Volume	Low , Medium, High	The Alarm Volume control sets the loudness of auditory alarm indicators. <div style="background-color: #e0e0e0; padding: 5px; border-radius: 5px;"> WARNING: Set the Alarm Volume loud enough to be heard over expected ambient noise (such as a vacuum cleaner). Failure to hear and respond to an alarm condition may result in patient harm or death. </div>
Calibrate Touchscreen	N/A	Use the Calibrate Touchscreen control to recalibrate the V*Home touchscreen. Perform a touchscreen recalibration if V*Home controls become difficult to select. After confirming the touchscreen recalibration and turning off the device, you will be asked to touch several areas on the screen when V*Home restarts. <div style="border: 1px solid #00a651; border-radius: 10px; padding: 5px; margin-top: 10px;"> NOTE: V*Home must be powered off and restarted to complete this procedure. </div>
Unlock Required?	No, Yes	Set the Unlock Required? control to Yes to require the use of a configuration password to access V*Home controls. Using the Permissions feature, you can configure which controls cannot be modified without first entering the Clinician Unlock password. See <i>"Clinician Access Mode"</i> on page 76 for more information. Whenever V*Home will be outside of the immediate control of a clinician, set the Clinician Unlock Required control to Yes to prevent the accidental activation of unintended therapies. <div style="border: 1px solid #00a651; border-radius: 10px; padding: 5px; margin-top: 10px;"> NOTE: Depending on the optional features purchased for use with V*Home, the default Clinician Unlock Required setting may be Yes. </div>
Language	[Language name in target language]	Use the Language control to change the text displayed in the V*Home operating system to a different language.
Date	N/A	The Date control sets the displayed date.
Reset Settings for New Patient	N/A	Selecting Reset Settings for New Patient will revert all V*Home controls to their default settings, and also reset trending data exported for Multi-View reporting. See <i>"Multi-View"</i> on page 102 for more information. V*Home will prompt you to confirm the reset before restoring factory default settings and resetting trend data.
Time	N/A	The Time control sets the displayed time.

Alarms

A V*Home alarm will activate whenever the device detects a condition that requires clinician or caregiver attention. Alarms will generate an audible tone, and/or a blue, yellow, or red alert banner across the top of the V*Home screen. V*Home has three alarm priority categories:

Alarm Priority	Visual Indicator	Auditory Indicator	Clinician or Caregiver Response
High	Red banner 	10 tones every 3 seconds	Requires immediate clinician or caregiver response
Medium	Yellow banner 	3 tones every 7 seconds	Requires prompt clinician or caregiver response
Low	Blue banner 	No auditory indicator	Requires clinician or caregiver attention

NOTE: An Inop alarm will generate a consistent audible tone and cause the On/Off button to flash red. In case of V*Home Inop alarm, immediately provide the patient with an alternate source of ventilation, and restart V*Home.

Set the Alarm Volume control so that alarm conditions are audible over ambient noise at all times, and at any anticipated distance away from V*Home the caregiver may travel. Ventec Life Systems recommends ensuring the Alarm Volume control is set appropriately by simulating these conditions and verifying the alarm can be heard. See *“Device Settings” on page 77* for Alarm Volume configuration instructions. Similarly, if you are using an optional remote alarm, ensure it is placed somewhere it can be heard at all times.

WARNING: In environments containing multiple V*Home devices, or similar devices set with different alarm limits (such as an intensive care unit), alarm conditions may be confused with other alarm sources. Failure to respond to an alarm condition quickly may result in patient harm.

NOTE: Auditory alarm indicators may be delayed for more than 10 seconds depending on the ventilation therapy configuration and the Patient Circuit Disconnect alarm setting, or the High Pressure Delay control setting.

Alarm Silence Button

V*Home will emit an audible series of tones whenever a high- or medium-priority alarm activates. Press the Alarm Silence button on the front of V*Home to silence the active alarm tones for 60 seconds. Press the Alarm Silence button again (or wait 60 seconds) to reactivate the alarm tones.

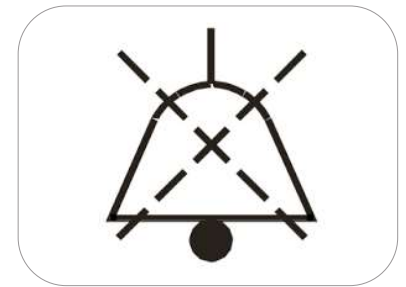

NOTE: The visual alarm (indicating the alarm condition and priority) will remain on the V*Home screen.

NOTE: The Internal Battery Critically Low alarm cannot be silenced until V*Home is plugged into an external source of power. To silence the alarm after plugging in V*Home, access the Alarm Log (by pressing the alarm banner in the upper left-hand corner of the screen or pressing [LOGS](#) in the Menu tab), and then select [CLEAR LIST](#).

Changing Alarm Settings

WARNING: The V*Home clinician is responsible for setting alarm limits appropriately for each patient condition. Do not set alarm limits to values that render the alarm system useless. Failure to set alarm limit values appropriately for the patient condition may result in patient harm.

To change ventilator alarm settings:

- 1 Press the [Menu](#) tab, or the [VENTILATION](#) button on the Therapy screen.
- 2 Press the [SETTINGS & ALARMS](#) button.
- 3 A Settings banner appears in the list first. Scroll down to the Alarms section.
- 4 Scroll to the applicable alarm and press its name.
- 5 Press [EDIT >](#) on the right side of the screen.
- 6 If the alarm has both low and high alarm limits, press the [L](#) icon to modify the low alarm limit, or the [H](#) icon to modify the high alarm limit. Enter the new alarm setting and press [ACCEPT](#) to save your selection.
- 7 Follow the procedure above to modify additional alarms. When configuration is complete, press the [< EXIT](#) tab.

Alarm Conditions and Settings

Possible alarm conditions and recommended actions are listed below. The following table also includes a description of each alarm and the range of alarm settings available. All possible alarm conditions are listed in alphabetical order.

NOTE: **Black** text indicates the default setting.

NOTE: Alarm settings are not affected by power interruption.

Alarm	Settings	Priority	Description	Recommended Action
Apnea	Off , 10 to 120 seconds 20 seconds	High	<p>The Apnea alarm activates when V*Home has not delivered assist or spontaneous breaths (or coughs) for the set Apnea alarm duration. When this alarm activates, mandatory breaths will be delivered to the patient at the set Apnea Rate.</p> <p>The Apnea alarm will deactivate when the patient triggers two consecutive assist and/or spontaneous breaths.</p> <p>The Apnea alarm can also be deactivated by pressing the Clear List button twice from the Alarm Log screen. See <i>"Clearing an Alarm"</i> on page 93 for detailed instructions.</p> <p>NOTE: In SIMV ventilation modes, set the Apnea alarm to at least twice the configured breath period (60 seconds divided by the set Breath Rate) to avoid nuisance alarms.</p>	<p>Monitor the patient closely to ensure adequate ventilation therapy is delivered.</p> <p>Check to ensure patient-triggered breaths are not delivered less often than necessary, and adjust the Flow Trigger control setting if needed.</p>
Battery Use	N/A	Medium	<p>The Battery Use alarm activates whenever V*Home switches from external power to battery power, or from any power source (including removable battery) to internal battery power.</p> <p>The Battery Use alarm remains active until it is reset by clearing the Alarm Log, or external power is connected to V*Home.</p>	<p>Monitor battery charge status, and connect an external source of power when available.</p>
Check O2 Source	On , Off	Medium	<p>The Check O2 Source alarm activates when a connected source of external low-pressure oxygen is used and the monitored FiO2 falls below 24%.</p> <p>Use the Check O2 Source alarm to detect oxygen source disconnects when the Oxygen Source control is set to Low Pressure O2 and High Flow therapy is Off.</p>	<p>Monitor the patient closely to ensure adequate Oxygen therapy is delivered.</p> <p>Verify the connected low-pressure oxygen source is on and is functioning correctly.</p>

Alarm	Settings	Priority	Description	Recommended Action																																												
<p>Check Patient Circuit</p>	<p>N/A</p>	<p>High</p>	<p>The Check Patient Circuit alarm activates when V*Home detects an inadequate leak in a passive or valveless circuit (see the chart below).</p> <div data-bbox="212 531 1138 1031" style="border: 1px solid #ccc; border-radius: 15px; padding: 10px; margin: 10px 0;"> <p style="text-align: center;">Check Patient Circuit Alarm Leak Threshold</p> <table border="1" style="display: none;"> <caption>Check Patient Circuit Alarm Leak Threshold Data</caption> <thead> <tr> <th>MAP (cmH2O)</th> <th>Leak (L/min)</th> </tr> </thead> <tbody> <tr><td>0</td><td>0</td></tr> <tr><td>1</td><td>3</td></tr> <tr><td>2</td><td>4.5</td></tr> <tr><td>3</td><td>5.5</td></tr> <tr><td>4</td><td>6.5</td></tr> <tr><td>5</td><td>7.5</td></tr> <tr><td>6</td><td>8.5</td></tr> <tr><td>7</td><td>9.5</td></tr> <tr><td>8</td><td>10.5</td></tr> <tr><td>9</td><td>11.5</td></tr> <tr><td>10</td><td>12.5</td></tr> <tr><td>11</td><td>13.5</td></tr> <tr><td>12</td><td>14.5</td></tr> <tr><td>13</td><td>15.5</td></tr> <tr><td>14</td><td>16.5</td></tr> <tr><td>15</td><td>17.5</td></tr> <tr><td>16</td><td>18</td></tr> <tr><td>17</td><td>18.5</td></tr> <tr><td>18</td><td>19</td></tr> <tr><td>19</td><td>19.5</td></tr> <tr><td>20</td><td>20</td></tr> </tbody> </table> </div>	MAP (cmH2O)	Leak (L/min)	0	0	1	3	2	4.5	3	5.5	4	6.5	5	7.5	6	8.5	7	9.5	8	10.5	9	11.5	10	12.5	11	13.5	12	14.5	13	15.5	14	16.5	15	17.5	16	18	17	18.5	18	19	19	19.5	20	20	<p>Check the passive exhalation valve is unobstructed (for passive circuits).</p> <p>Run a Pre-Use Test.</p> <p>Monitor the patient closely to ensure adequate Ventilation and Oxygen therapy is delivered.</p> <p>If the problem persists, connect the patient to an alternate source of ventilation and contact your local Ventec Life Systems representative for service.</p>
MAP (cmH2O)	Leak (L/min)																																															
0	0																																															
1	3																																															
2	4.5																																															
3	5.5																																															
4	6.5																																															
5	7.5																																															
6	8.5																																															
7	9.5																																															
8	10.5																																															
9	11.5																																															
10	12.5																																															
11	13.5																																															
12	14.5																																															
13	15.5																																															
14	16.5																																															
15	17.5																																															
16	18																																															
17	18.5																																															
18	19																																															
19	19.5																																															
20	20																																															
<p>High Breath Rate</p>	<p>Off, 10 to 99 BPM</p>	<p>Medium</p>	<p>The High Breath Rate alarm will activate when the monitored breath rate is higher than the set High Breath Rate alarm limit.</p>	<p>Monitor the patient closely to ensure adequate ventilation therapy is delivered.</p>																																												
<p>High FiO2</p>	<p>Off, 24 to 99%</p>	<p>Medium</p>	<p>When using High Flow therapy with bleed-in oxygen, the High FiO2 alarm activates when the monitored FiO2 percentage is higher than the set High FiO2 alarm limit.</p> <p>Set the High FiO2 alarm appropriately for the patient condition whenever using Low Pressure O2 with High Flow therapy.</p> <div data-bbox="638 1503 1195 1629" style="border: 1px solid #ccc; border-radius: 10px; padding: 5px; margin: 5px 0;"> <p>NOTE: If the FiO2 monitor is inactive, the High FiO2 alarm will be disabled. See "<i>FiO2 Monitor</i>" on page 99 for more information.</p> </div> <div data-bbox="638 1671 1174 1864" style="border: 1px solid #ccc; border-radius: 10px; padding: 5px; margin: 5px 0;"> <p>NOTE: While using Low Pressure O2, the FiO2 monitor and alarms are available during High Flow therapy only. Deactivating High Flow therapy while using Low Pressure O2 will also deactivate the FiO2 monitor and alarms.</p> </div>	<p>Monitor the patient closely.</p> <p>If the problem persists, contact your local Ventec Life Systems representative for service.</p>																																												

Alarm	Settings	Priority	Description	Recommended Action
High Minute Volume	Off , 1 to 59 L	Medium	<p>The High Minute Volume alarm activates when the monitored Minute Volume is larger than the set High Minute Volume alarm limit.</p> <p>NOTE: The High Minute Volume alarm will not activate when the Circuit Type control is set to Mouthpiece.</p>	<p>Monitor the patient closely.</p> <p>If the monitored Breath Rate is high, check to ensure patient-triggered breaths are not delivered more often than necessary, and adjust the Flow Trigger control setting if needed.</p> <p>If you are using an active Ventec One-Circuit and humidifier, clear any condensation from the active exhalation valve.</p>
High PEEP (High EPAP in Bi-Level Mode)	Off , 3 to 20 cmH ₂ O above set PEEP 5 cmH ₂ O	Medium	<p>The High PEEP alarm activates when the monitored PEEP is greater than PEEP plus the set High PEEP alarm limit.</p>	<p>Monitor the patient closely.</p> <p>Check for breath auto-cycling or breath stacking.</p> <p>If the problem persists, replace the Ventec One-Circuit.</p>
High Pressure	10 to 80 cmH ₂ O 40 cmH₂O	High	<p>The High Pressure alarm activates when the monitored Airway Pressure exceeds the set High Pressure alarm limit for more than the number of consecutive breaths set with the High Pressure Delay control.</p> <p>When used with High Flow therapy, set the alarm above the normal operating pressure to detect circuit occlusions.</p> <p>NOTE: V*Home will limit the pressure of breaths to the High Pressure alarm setting, and the (H) indicator will flash red every time the High Pressure alarm setting is exceeded, regardless of the High Pressure Delay setting.</p>	<p>Monitor the patient closely and check for reduced patient lung compliance during volume ventilation.</p> <p>Check the Ventec One-Circuit for occlusions.</p>
Inop	N/A	[Technical Alarm]	<p>The Inop alarm activates when V*Home experiences a loss of power without available battery backup power, when the battery depletes and is the only available source of power, or when a software or hardware failure renders V*Home unable to safely deliver therapy and/or monitor the patient.</p>	<p>Immediately provide the patient with an alternate source of ventilation.</p> <p>Press the On/Off button again to restart V*Home. If the device remains inoperative, contact your local Ventec Life Systems representative for service.</p>

Alarm	Settings	Priority	Description	Recommended Action
Internal Battery Critically Low	N/A	High	<p>The Internal Battery Critically low alarm activates when the internal battery is disconnected, faulty, or when the battery is critically low (charged to less than 33% its capacity).</p> <p>NOTE: The Internal Battery Critically Low alarm condition cannot be cleared or silenced until V*Home is connected to external power. Connect external power and press the Clear List button twice from the Alarm Log screen to silence and clear the alarm.</p>	<p>Immediately connect V*Home to a continuous source of external power and verify the charge status indicator light on the front of V*Home illuminates.</p> <p>Clear the alarm by selecting CLEAR LIST in the Alarm Log.</p> <p>If alarm persists after application of external power, provide the patient with an alternate source of ventilation therapy.</p>
Internal Battery Low	N/A	Medium	<p>The Internal Battery Low alarm activates when V*Home internal battery charge status falls below 50%.</p> <p>NOTE: The Internal Battery Low alarm may be silenced, but the condition cannot be cleared until V*Home is connected to external power.</p> <p>NOTE: Because the battery capacity diminishes over time, this alarm may activate more quickly as the battery ages.</p>	<p>Promptly connect V*Home to a continuous source of external power.</p> <p>Clear the alarm by selecting CLEAR LIST in the Alarm Log.</p> <p>If the alarm persists after several hours of external power connection, contact your local Ventec Life Systems representative for service.</p>
Low Breath Rate	Off, 4 to 80 BPM 5 BPM	Medium	<p>The Low Breath Rate alarm activates when the monitored Breath Rate is less than the set Low Breath Rate alarm limit.</p>	<p>Monitor the patient closely to ensure adequate Ventilation therapy is delivered.</p> <p>Check to ensure patient-triggered breaths are not delivered less often than necessary, and adjust the Flow Trigger control setting if needed.</p>

Alarm	Settings	Priority	Description	Recommended Action
Low FiO2	Off , 19 to 92%	Medium	<p>The Low FiO2 alarm activates when the monitored FiO2 falls below the set Low FiO2 alarm limit.</p> <p>Set the Low FiO2 alarm appropriately for the patient condition whenever using Low Pressure O2 with High Flow therapy.</p> <p>NOTE: If the FiO2 monitor is inactive, the Low FiO2 alarm is disabled. See <i>"FiO2 Monitor"</i> on page 99 for more information.</p> <p>NOTE: While using Low Pressure O2, the FiO2 monitor and alarms are only available during High Flow therapy. Deactivating High Flow therapy while using Low Pressure O2 will also deactivate the FiO2 monitor and alarms.</p>	<p>Monitor the patient closely to ensure adequate Oxygen therapy is delivered.</p> <p>Verify the connected low-pressure oxygen source is on and is not depleted.</p>
Low Flow	n/a	Medium	<p>The Low Flow alarm activates automatically during High Flow therapy when V*Home detects that the internal ventilator flow is less than 50% of the target flow for more than five minutes.</p> <p>NOTE: The Low Flow alarm is present in software versions 5.00 and later only.</p>	<p>Monitor the patient closely to ensure adequate High Flow therapy is delivered.</p> <p>If the problem persists, connect the patient to an alternate source of High Flow therapy and contact your local Ventec Life Systems representative for service.</p>
Low Inspiratory Pressure	Off , 1 to 40 cmH2O 10 cmH2O	High	<p>The Low Inspiratory Pressure alarm activates when the monitored Peak Inspiratory Pressure falls below the set Low Inspiratory Pressure alarm limit.</p> <p>NOTE: Ventec Life Systems recommends using the Low Inspiratory Pressure and Low Minute Volume alarms to detect hypoventilation.</p>	<p>Check the Ventec One-Circuit for leaks or disconnection.</p> <p>Monitor the patient closely to ensure adequate ventilation therapy is delivered.</p> <p>If the problem persists, connect the patient to an alternate source of ventilation and contact your local Ventec Life Systems representative for service.</p>

Alarm	Settings	Priority	Description	Recommended Action
Low Minute Volume	Off, 0.1 to 9.9 L, 10 to 50 L 2.5 L	High	<p>The Low Minute Volume alarm activates when the monitored Minute Volume falls below the set Low Minute Volume alarm limit.</p> <p>NOTE: Ventec Life Systems recommends using the Low Minute Volume and Low Inspiratory Pressure alarms to detect patient hypoventilation.</p> <p>WARNING: If the Low Minute Volume alarm cannot be set appropriately for the patient condition because of a connected speaking valve or other reason, use an alternate respiratory monitor such as an oximeter or cardio-respiratory monitor to detect hypoventilation.</p>	<p>Monitor the patient closely to ensure adequate ventilation therapy is delivered.</p> <p>Check the Ventec One-Circuit for leaks or disconnection.</p> <p>During pressure-control ventilation, check the patient for reduced lung compliance or airway occlusion.</p>

Alarm	Settings	Priority	Description	Recommended Action
Low PEEP (Low EPAP in Bi-Level Mode)	On, Off	Medium	The Low PEEP alarm activates when the monitored PEEP falls 5 cmH ₂ O below the set PEEP control for 3 consecutive breaths.	Check the Ventec One-Circuit for leaks. Monitor the patient closely. If the problem persists, replace the Ventec One-Circuit.
Maintenance Due	N/A	Low	The Maintenance Due alarm activates when the Sys. PM Due In monitor is at or below 0, indicating that V*Home is due for maintenance. This alarm can be reset for up to 32 hours by clearing the alarm. (Software versions 4.13 and earlier will reset the alarm for 8 hours.)	Contact your local Ventec Life Systems representative for service.
Patient Circuit Disconnect (see below for modified alarm settings during High Flow therapy)	Off, 1-15 breaths (leak up to 75 L/min), 1-15 breaths (leak 75 to 175 L/min) 4 breaths (leak 75 to 175 L/min) NOTE: If the sensitivity toggle is not available, the more sensitive setting (0-75) is always active	High	<p>The Patient Circuit Disconnect alarm activates when V*Home detects a large leak in a passive or valveless Ventec One-Circuit.</p> <p>The toggle at the top of the control editing window can be used to turn the alarm on or off.</p> <p>Use the numeric keypad to set the alarm delay. The Patient Circuit Disconnect alarm will activate in one breath plus the set number of breath cycles. For example, when set to 3, the alarm will activate on the 4th disconnect breath.</p> <p>The SENSITIVITY toggle changes the threshold at which the Patient Circuit Disconnect alarm activates. The 0-75 setting is intended for use with small and medium leaks, to ensure the alarm is sensitive enough to detect disconnects and most decannulations. The 75-175 setting desensitizes the alarm to reduce nuisance alarms when used with large leaks around the patient interface.</p> <div style="border: 1px solid gray; padding: 5px; background-color: #f0f0f0;"> <p>PRECAUTION: Always test the Patient Circuit Disconnect alarm before use to verify it detects disconnects and/or decannulations with the specific patient conditions, patient interface, and V*Home settings.</p> </div>	Check the Ventec One-Circuit for leaks or disconnection. Monitor the patient closely to ensure adequate Ventilation therapy is delivered. If the problem persists, connect the patient to an alternate source of ventilation and contact your local Ventec Life Systems representative for service.

Alarm	Settings	Priority	Description	Recommended Action
-------	----------	----------	-------------	--------------------

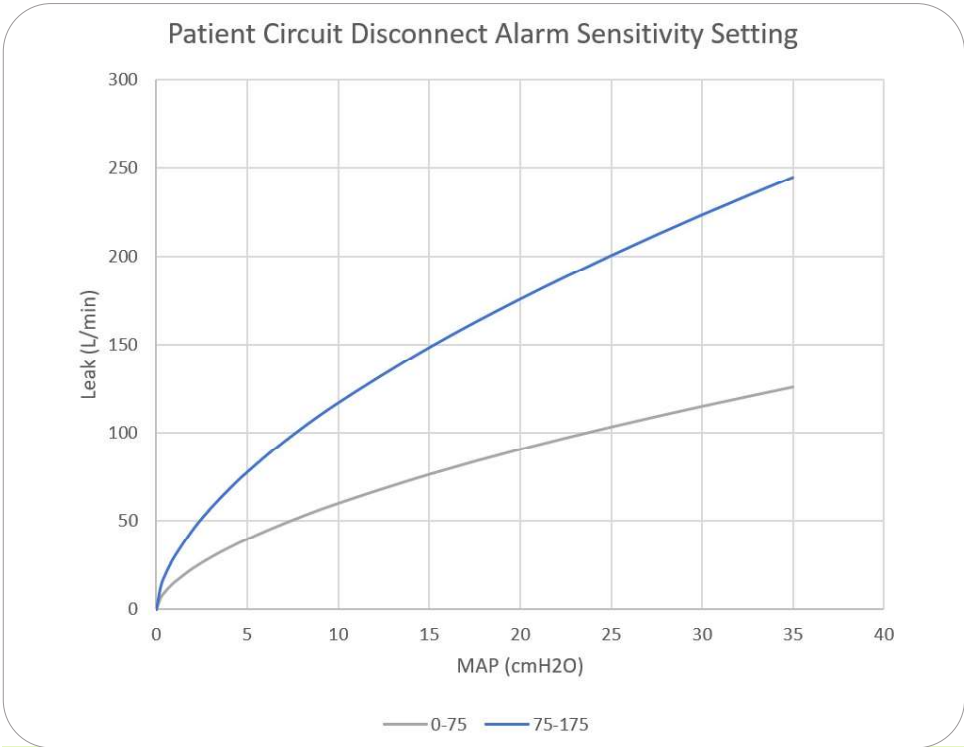

The graphic to the left shows how the **SENSITIVITY** setting interacts with leaks at various Mean Airway Pressures (MAPs):

NOTE: The Patient Circuit Disconnect alarm may not activate with every disconnect condition. Ventec Life Systems recommends using the Low Minute Volume, Low Inspiratory Pressure, and Apnea alarms in addition to the Patient Circuit Disconnect alarm to ensure Ventec One-Circuit disconnections are detected.

<p>Patient Circuit Disconnect (during High Flow therapy)</p>	<p>Off, Low Sensitivity, Medium Sensitivity, High Sensitivity</p>	<p>High</p>	<p>During High Flow therapy, the Patient Circuit Disconnect alarm will activate when no patient breathing is detected for 20 seconds.</p> <p>The Low Sensitivity setting is appropriate for use with smaller patients with smaller spontaneous breathing efforts. High Sensitivity makes the alarm more sensitive, and is appropriate for larger patients with larger spontaneous breathing efforts.</p> <div style="border: 1px solid gray; border-radius: 10px; padding: 10px; background-color: #f0f0f0;"> <p>PRECAUTION: During High Flow, the Patient Circuit Disconnect alarm may activate when the nasal cannula is connected to some patients (such as those with small spontaneous breathing efforts and using resistive nasal cannulas). In these instances, turn the Patient Circuit Disconnect alarm Off and provide continuous monitoring, such as pulse oximetry. Always test the Patient Circuit Disconnect alarm before use with High Flow therapy to verify it functions with the specific patient conditions, patient interface, and V*Home settings.</p> </div>	<p>Ensure the high flow nasal cannula (or other interface) is properly fitted to the patient.</p> <p>Monitor the patient closely.</p> <p>If the problem persists, connect the patient to an alternate source of ventilation and contact your local Ventec Life Systems representative for service.</p>
---	--	-------------	---	--

Alarm	Settings	Priority	Description	Recommended Action
System Fault (all conditions)	N/A	High	The System Fault alarm activates if V*Home detects any one of multiple system fault conditions.	Use the Event Log to determine the System Fault number, and then see <i>"System Fault Detection Criteria and Recommended Action"</i> on page 177 and take the corresponding action.
Very Low FiO2	N/A	High	The Very Low FiO2 alarm activates when the monitored FiO2 is less than 18%. <div style="border: 1px solid black; border-radius: 10px; padding: 5px; margin-top: 10px;"> NOTE: If the FiO2 monitor is inactive, the Very Low FiO2 alarm will be disabled. See <i>"FiO2 Monitor"</i> on page 99 for more information. </div>	Remove any gas source connected to V*Home and monitor the patient.

The Alarm Log

The V*Home Alarm Log lists all active alarms, and all other alarms activated since the last time the log was cleared.

To view the V*Home Alarm Log at any time, press the alarm banner in the status bar, or:

- 1 Press the [Menu](#) tab.
- 2 Press the [LOGS](#) button.
- 3 If needed, press the [Alarms](#) tab.
- 4 Scroll down on the page to see additional alarms.



To clear the list of all but the active alarm conditions, press the [CLEAR LIST](#) button from the Alarm Log screen. Information about the alarm will also be stored in the V*Home Event Log, which cannot be deleted.

The Mark Event Button

The Mark Event button appears in software versions 5.00 and later only. This button is accessible from the Alarm Log screen, or the Quick Access menu, and provides a means to create a marker in the device Event Log and Multi-View data.

When an interesting or noteworthy event occurs during therapy that you'd like to mark, press this button. A pin will appear in your Multi-View data at that moment of time, so that therapy information surrounding the event can be analyzed.



The Event Log

The Event Log stores the date and time of unit power on and off, alarm activation, the alarm name, and information about user interactions with the V*Home alarm system and controls. The most recent 7,300 events, including alarms and changes to control settings will be accessible through the Event Log. As the V*Home Event Log reaches capacity, the oldest Event Log records will be overwritten one at a time as new logs are created. Events in the Event Log cannot be deleted.

NOTE: The Event Log, including information about activated alarms, is retained through V*Home shut down. The Event Log will be stored for at least 365 days after a total loss of device power.

To view the VOCSN Event Log:

- 1** Press the **Menu** tab.
- 2** Press the **LOGS** button
- 3** If needed, press the **Events** tab.
- 4** Scroll down on the page to see additional events. Press the forward and back page navigation buttons to see additional events.

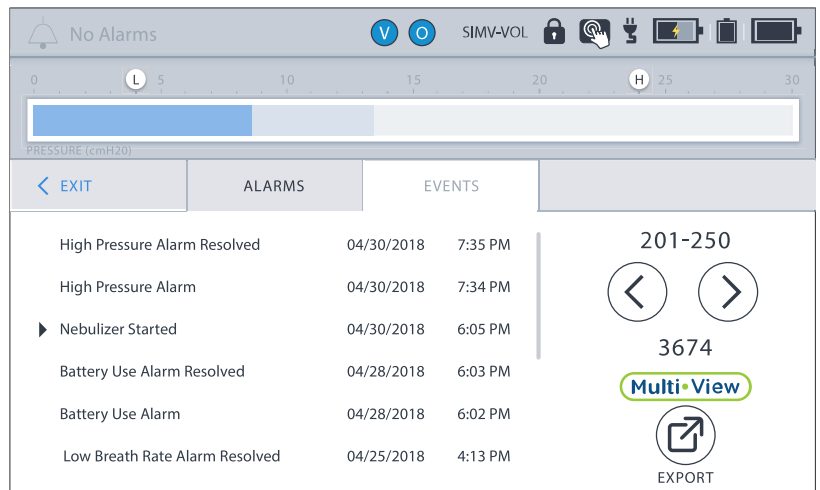

NOTE Timestamps on events in the V*Home Event Log (and Alarm Log) are based on the configured V*Home Date and Time setting at the time the event occurred. If the V*Home Date and Time settings are incorrect, the timestamps shown in the log will also be incorrect, and cannot be corrected. However, V*Home Multi-View timestamps are relative, and will recalculate based on the most recent V*Home Date and Time setting when data is exported and a report is generated.

NOTE: For more information on V*Home Multi-View trend reporting, see "Multi-View" on page 102.



Clearing an Alarm

Visual indicators of an alarm condition remain on the screen as a count in the status bar and a list in the Alarm Log until the alarm condition is resolved and the list is cleared. To clear an activated alarm:

- 1 Press the Alarm Silence button on the front of V*Home to silence the alarm tones, if desired.
- 2 Resolve the alarm condition by taking the appropriate action. When an alarm condition is resolved, the alarm will clear. A log of the alarm activation will be recorded in the Alarm Log and the Event Log.
- 3 Access the Alarm Log through the Menu tab, or by pressing the Alarm banner in the upper left corner of the V*Home touchscreen, then select [CLEAR LIST](#) to remove all but active alarms from the Alarm Log.

NOTE: A record of recent alarm conditions will remain in the Event Log, even when the Alarm Log has been cleared.

- 4 Press the [< EXIT](#) tab to exit the Alarm Log.

Remote Alarms and Nurse Call Systems (Optional)

Connect an optional remote alarm or nurse call system using the port on the back of V*Home. See *"Connecting a Nurse Call System or Remote Alarm"* on page 33 for setup information.

NOTE: The delay between an alarm condition and activation of the remote alarm port is <1 s. Refer to the remote alarm manufacturer's instructions for use to determine the maximum possible delay between V*Home alarm and remote alarm activation.

Monitors

V*Home monitors multiple parameters. View monitored V*Home Ventilation therapy data by pressing the Monitors tab. Oxygen and Nebulizer therapy monitors are available by navigating to the relevant therapy screen.

NOTE: Monitored data depends on the set Circuit Type, Mode, and the number of breaths delivered. Monitors will display "--" if they are not available for the set Circuit Type or Mode. V*Home will display a spinning circle graphic while it is calculating a monitored value.

From the Monitors tab, press the **CUSTOMIZATION** button to configure which monitors display on the screen. The three monitors configured to display on the top row of the Monitors tab will appear on the Home screen.

Press the **WAVEFORMS** button to view real-time flow, volume, and pressure Ventilation therapy waveforms.

NOTE: When used with passive and valveless Ventec One-Circuits, V*Home was designed for use with a humidifier or HME. All volumes and flows are expressed in BTPS unless stated otherwise.

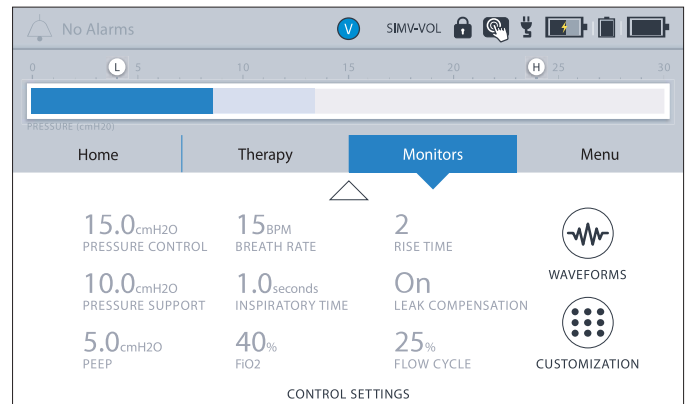
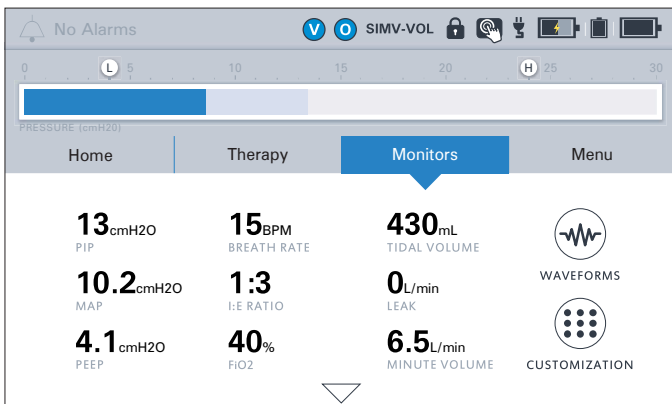

Ventilation Monitors

Monitored Ventilation therapy parameters and active control settings can be viewed using the Monitors tab on the V*Home touchscreen. The displayed monitors and controls are customizable. To change which monitors and control settings display on the Monitors tab, see *"Monitor Screen Customization" on page 98*.

Press the down arrow at the bottom of the Monitors screen to view currently active Ventilation and Oxygen therapy control settings.

V*Home will only display the monitors applicable to the delivered therapy. The table below lists these dependencies. For more information about the monitors available during mouthpiece ventilation, see *"Setting V*Home Controls for Mouthpiece Ventilation" on page 71*.

V*Home continuously monitors the following parameters during Ventilation therapy:

Monitor	Range	Description
Breath Rate	0 to 100 BPM	Breath Rate. Provides a calculation of the average number of breaths per minute (BPM) delivered to the patient based on the previous 8 breaths.
EPAP (Bi-Level ventilation modes only)	0 to 45 cmH ₂ O	Expiratory Positive Airway Pressure. The EPAP monitor displays the pressure maintained between breaths (from the end of exhalation). NOTE: The EPAP monitor is only available when the Ventilation Mode is set to Bi-Level.
Estimated Vte (Passive and Valveless Ventec One-Circuits only)	0 to 2000 mL	Estimated Exhaled Tidal Volume. When Circuit Type is set to Passive or Valveless, VOCSN will calculate the estimated volume of the last patient exhalation. This monitor is based on internal VOCSN calculations, rather than a measurement. WARNING: The accuracy of Vte measurements may be affected by large leaks at the patient interface.
FiO₂	15 to 95%, >95%	See <i>"Oxygen Therapy Monitors" on page 99</i> .
Flow Setting	4 to 60 L/min	During High Flow therapy, the Flow Setting monitor displays the Flow control setting.
Flow waveform	User Scalable	Real-time Ventilation therapy flow waveforms are visible by pressing the WAVEFORMS button from the Monitors tab. See <i>"Waveform Monitors" on page 97</i> for more information.

Monitor	Range	Description
I:E Ratio	9.9:1 to 1:9.9	The I:E Ratio monitor displays the average ratio between inspiratory and exhalation time over the last 8 breaths.
Leak	0 to 200 L/min	The Leak monitor displays the flow of gas leaking during each breath in L/min.
MAP	0 to 50 cmH ₂ O	Mean Airway Pressure. The MAP monitor displays the average pressure delivered throughout the breath period of the last eight breaths.
Minute Volume	0 to 60 L	The Minute Volume monitor displays the calculated volume of air delivered to the patient over one minute, based on the average breath rate and V _{te} (for active circuits) or Estimated V _{te} (for passive and valveless circuits) of the last eight breaths.
Patient Effort	N/A	<p>The patient effort icon appears on the left side of the airway pressure manometer in the status bar when V*Home delivers a patient-triggered breath.</p> <p>NOTE: Ventec Life Systems recommends periodically verifying that the Patient Effort indicator in the status bar appears in synchrony with actual patient effort to breathe.</p>
Patient Triggered	0 to 100%	The Patient Triggered monitor displays the percentage of the last 100 breaths that were initiated by the patient.
Peak Exh Flow	0 to 200 L/min	Peak Exhalation Flow. Measures the maximum expiratory flow during exhalation.
Peak Insp Flow	0 to 200 L/min	Peak Inspiratory Flow. Measures the maximum inspiratory flow during inhalation.
PEEP	0 to 45 cmH ₂ O	<p>Positive End Expiratory Pressure. The PEEP monitor displays the pressure maintained between breaths (from the end of exhalation).</p> <p>NOTE: During Bi-Level ventilation, the EPAP monitor is in use, instead.</p>
PIP	0 to 85 cmH ₂ O	Peak Inspiratory Pressure. The PIP monitor displays the maximum pressure delivered during the last breath.

Monitor	Range	Description
Pressure (during Ventilation therapy)	0 to 80 cmH ₂ O	Airway Pressure is monitored using a manometer in the status bar. The dark blue bar represents the pressure of the current breath. The light blue bar represents the peak pressure delivered during the previous breath.
Pressure waveform	User Scalable	Real-time pressure waveforms are visible by pressing the WAVEFORMS button from the Monitors screen. See <i>"Waveform Monitors"</i> on page 97 for more information.
Volume waveform	User Scalable	Real-time Ventilation therapy volume waveforms are visible by pressing the WAVEFORMS button from the Monitors tab. See <i>"Waveform Monitors"</i> on page 97 for more information.

Waveform Monitors

Press the **WAVEFORMS** button from the Monitors screen to access real-time, scalable Ventilation therapy waveforms. The screen displays any two of the following three available waveforms: pressure, flow, and volume.

To vertically scale the waveforms, click the up and down button next to the waveform. Use the left and right button to modify the time scale of the waveform. Use the pause button to stop the waveform at any time. When the play button is pressed, the waveforms will resume displaying real-time monitored waveform data. Press the waveform button again to switch between pressure, flow, and volume waveforms.



Monitor Screen Customization

Press the **CUSTOMIZATION** button from the Monitors tab to choose which monitors and control settings display on each page of the V*Home Monitor screen. The first page shows a customizable set of nine monitors. The second page shows a customizable set of nine control, alarm, and oxygen settings.



NOTE: The monitors selected for the top row of the Monitors tab will display on both the Monitors and the Home tab.

To customize the Monitors screen:

- 1** Press the **CUSTOMIZATION** button on the Monitors tab, and then press the monitor (or control setting) you want to modify.
- 2** Press **EDIT >** on the right side of the screen.
- 3** Press the name of the monitor you want to appear in the highlighted screen location.
- 4** Press **ACCEPT** to confirm your selection.
- 5** Press another monitor and repeat the steps above to make additional changes, or press the **< EXIT** tab near the top of the screen to exit the customization screen.

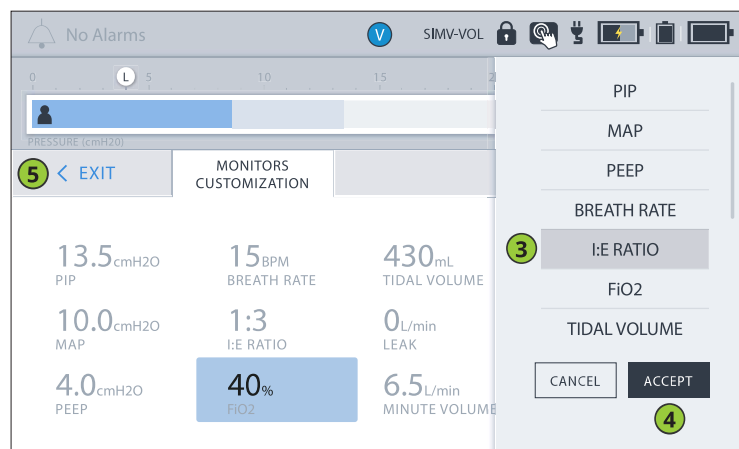
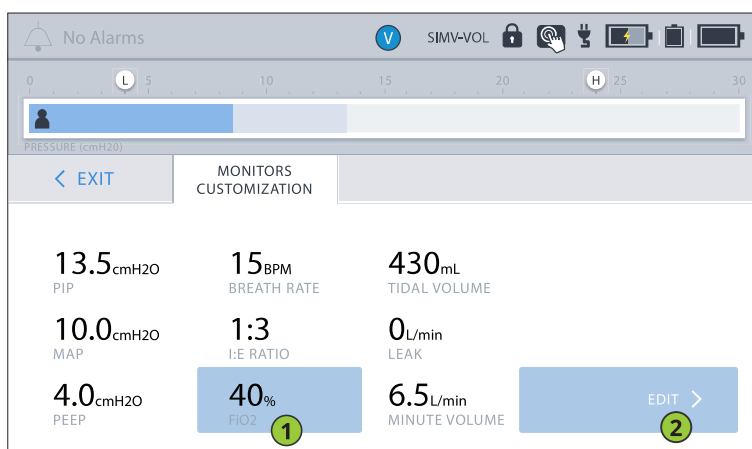

Oxygen Therapy Monitors

Use the FiO2 monitors to provide information about the percentage of oxygen inhaled by the patient.

FiO2 Monitor

Fraction of inspired oxygen. The FiO2 monitor measures the percentage of oxygen delivered in the inspiratory phase of each breath when using the FiO2 control with an external source of low-pressure oxygen.¹

If enabled and active, the FiO2 monitor is visible from the Monitors tab, or from the Oxygen therapy screen.

To activate and use the FiO2 monitor, it must be enabled (see *“Enabling and Disabling Prescribed Therapies”* on page 72), the Oxygen Delivery Mode control must be set to O2 Bleed In (see *“Oxygen Controls”* on page 73). When the FiO2 monitor is inactive, the High FiO2, Low FiO2, and Very Low FiO2 alarms are also inactive.

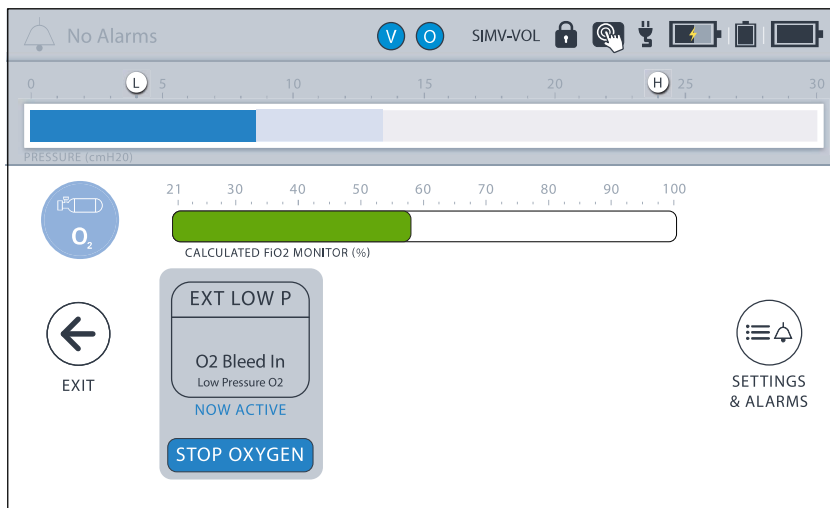

NOTE: The FiO2 monitor requires time to warm up. During the first five minutes of use, the FiO2 monitor will display "--" as the FiO2 value. The FiO2 monitor will also display dashes if the FiO2 monitor is disabled.

NOTE: The FiO2 monitor is equipped with automatic barometric pressure compensation.

NOTE: Performance of the FiO2 monitor may be affected by high humidity, cyclical pressure, or other sources of interference.

¹ The FiO2 monitor and alarms are also available when using low-pressure oxygen during High Flow therapy.

Nebulizer Compensation Monitor

Once Nebulizer compensation is initiated, the Nebulizer screen will display a Nebulizer Minutes Remaining monitor. This monitor begins at the configured Nebulizer Duration and counts down until Nebulizer therapy is complete.

NOTE: The range of the Nebulizer Minutes Remaining monitor is 0 to 60 minutes.

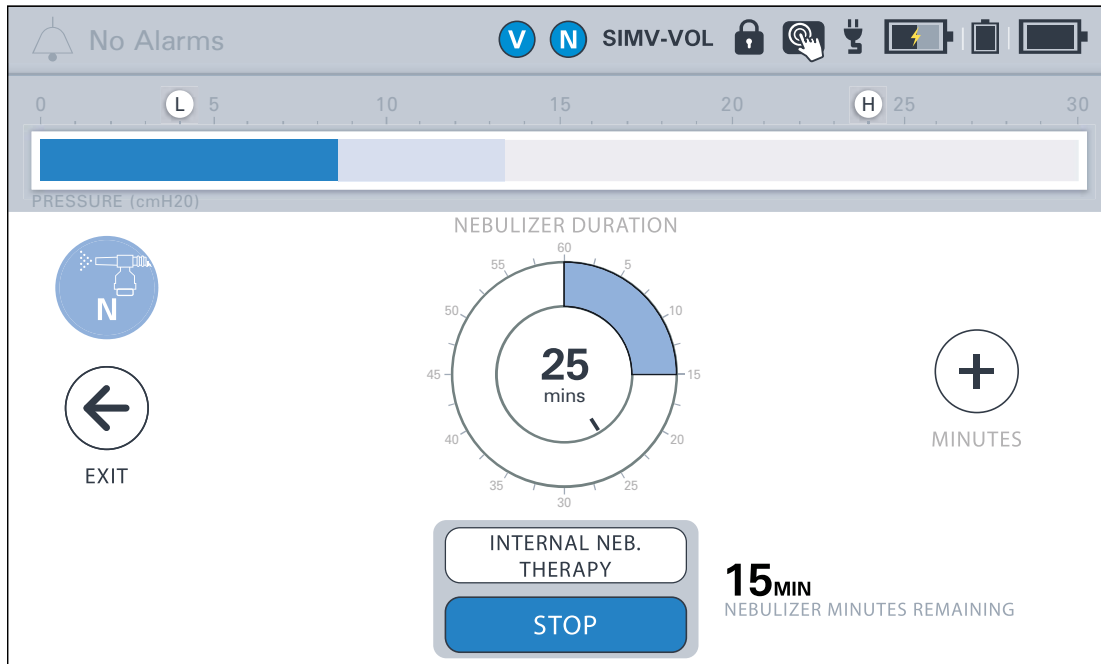

System Monitors

V*Home monitors the following system parameters. To view these monitors, press the [MY VOCSN](#) button from the Menu tab.

Monitor	Range	Description
Date	2016-01-01 to 2030-12-31	The Date monitor displays the configured date. Periodically check that the date setting is correct. To update the set Date setting, see <i>"Changing Device Settings" on page 78.</i>
Sys. PM Due In	-99,999 to 10,000 hours	The Sys. PM Due In monitor displays the time remaining in hours until the next preventative maintenance activities should be performed. A negative number indicates how many hours the maintenance is past due. Resetting this monitor requires service-level access to the system. Contact your local Ventec Life Systems representative for service.
System Usage	0 to 99,999 hours	The System Usage monitor displays the total duration of V*Home operation over its life.
Time	12:00 AM to 11:59 PM	The Time monitor displays the configured time. Periodically check that the time setting is correct. To update the Time setting, see <i>"Changing Device Settings" on page 78.</i>

Multi-View

VOCSN Multi-View is the first comprehensive reporting solution for ventilator-dependent patients.

It is the first and only system to provide complete patient trending and monitoring for ventilator-dependent patients across multiple respiratory therapies. Multi-View is designed to summarize patient data and create trend reports to facilitate the delivery of seamless care across providers from hospital to home. The streamlined information is designed to provide a comprehensive picture of the patient's respiratory wellbeing that has never before been possible.



NOTE: Multi-View reports are for informational purposes only. Clinical decisions should be made based on observations of the patient, not solely the report.

NOTE: Use the [Reset Settings for New Patient](#) control in the [Device Settings](#) to restore V*Home factory defaults and also reset Multi-View calculations. Reports generated after this event will display data from the time of this event forward.

Exporting Multi-View Data to a USB Drive

Using software versions 4.06 and later, V*Home data can be exported to USB, then uploaded to the cloud to create Multi-View trending reports, which provide insight into the use of all 5 therapies over time including the frequency of alarms, settings changes, and monitored parameter trends.

To export Multi-View data to USB:



- 1 Install a USB drive into the USB port in the back of V*Home.

NOTE: USB drives used with V*Home must be USB 2.0 compatible, and formatted to FAT32. Do not plug anything else into the V*Home USB port. To purchase a V*Home compatible USB drive, see VentecLife.com/usdrive.

- 2 Navigate to the Event Log by pressing **Menu** and then the **LOGS** button. Press the **Events** tab.
- 3 Select the **EXPORT** button to begin exporting Multi-View data to the connected USB drive. When the export is complete, press **OK** and remove the USB drive.

NOTE: V*Home stores and exports Multi-View data for the past 90 calendar days of use. Previous data is overwritten.

- 4 Insert the USB drive into a computer, and open the "VOCSN" folder on the drive. Ensure you're connected to the Internet and double-click the "Click to open Multi-View.html" link to open the Multi-View portal. Follow the instructions on the Multi-View portal, and see "[Generating Multi-View Reports](#)" on page 104 for more information.

Generating Multi-View Reports

To generate Multi-View usage reports, have your VOCSN Multi-View exports at the ready on a USB or folder on your computer, and then:

1 Use the “Click to open Multi-View.html” link or use a web browser to navigate to VentecLife.com/Multi-View.

2 You can upload VOCSN Multi-View files to the report generator portal by dragging and dropping the “Multi-View_Exports” folder from your USB drive or computer, or by selecting “Browse” and finding the files you would like to generate reports from.

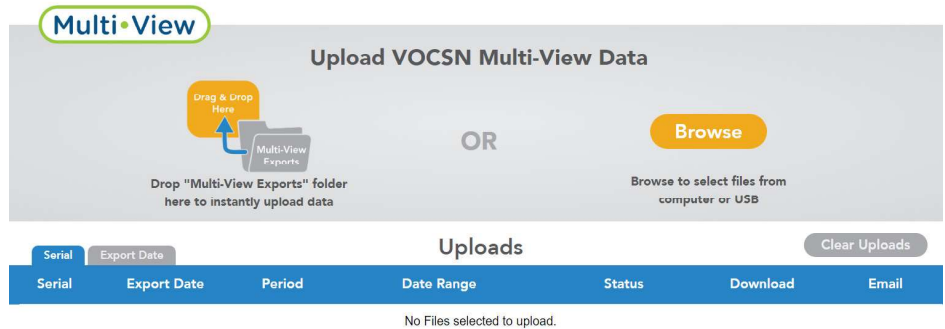

3 Whether you are uploading multiple files or just one, a pop-up window will appear allowing you to choose which report sections you would like to include, and what time period (and trend window) you would like the report to cover.

4 Make your selections and then click the “Create Reports” button to begin generating reports.

NOTE: To generate multiple reports with different durations from the same export file, create and download/email the first report, then select “Clear Uploads” and create the second.

5 The portal will begin processing the selected files immediately. When the “Status” column shows “Complete,” you can download the report PDFs individually, as a group, or email them directly from the portal using the buttons on the right-hand side of the page.

Uploads							Clear Uploads
Serial	Export Date	Period	Date Range	Status	Download	Email	
113454	1/6/2020	7 Days	12/30/2019 13:16 to 1/6/2020 13:16	Complete			
113804	1/6/2020	7 Days	12/30/2019 13:15 to 1/6/2020 13:15	Processing	---	---	
113823	1/6/2020	7 Days	12/30/2019 13:16 to 1/6/2020 13:16	Queued	---	---	
113830	1/6/2020	7 Days	12/30/2019 13:10 to 1/6/2020 13:10	Queued	---	---	

Reading Multi-View Reports

This section provides detailed information on using and reading VOCSN Multi-View reports. Each section of the report provides insight into aspects of V*Home therapy use and monitored trends.

Report Information

The first page of VOCSN Multi-View reports contain information about the V*Home device, as well as the report itself. This page includes the device serial number, its configuration and the software version installed at the time of the Multi-View export. It also includes information about the report creation date, duration, and the date and time range of data included.



Report Information

Serial Number	112848		
Configuration	V+O+C+S+N+Pro		
Report Creation Date	1/15/2020		
Report Duration	1-Week (data trended from last 24 hours)		
Report Date Range	1/7/2020 8:54 - 1/14/2020 8:54		
Report Sections	Trend Summary Settings Summary Alarm Summary	Monitor Details Therapy Log Alarm Log	Config Log Event Log
Patient	<input type="text"/>		
Patient Reference ID	<input type="text"/>		
Date of Birth	<input type="text"/>		
Equipment Used	<input type="text"/>		
Physician	<input type="text"/>		
Affiliation or Institution	<input type="text"/>		
Comments	<input type="text"/>		

This report is for informational purposes only. Clinical decisions should be made based on observations of the patient, not solely this report.

NOTE: To maintain data continuity, the dates and times used to display Multi-View data are anchored to the most recent V*Home Date and Time control settings. Unlike the Event Log displayed on the V*Home screen (which stamps events with whatever the V*Home Date and Time settings were at the time the event occurred), Multi-View time is calculated backwards so that event times are relative to the most recent setting. This approach ensures the continuity of graphed and trended data in Multi-View reports, even through time zone, daylight savings, or other changes to the Date and Time controls on V*Home.

The report cover page also includes user-editable fields that can be used to record additional information about the report. To use these fields, open the PDF file, click one of the blank line items, and type in the desired value. Saving the report will also save the date you entered.

NOTE: If you need to ensure that the data you enter into the form fields cannot be edited again, use a PDF reader to fill in the fields, and then select "Print" to print the file to PDF and lock your entries in place in the new file.

Trend Summary

The Multi-View Trend Summary section provides information on all available therapies, including daily usage information, monitor averages, and trends.

Each box shows a different monitored parameter. The displayed average is calculated over the selected report duration. 7-day reports will include a 7-day average, 60-day reports will include a 60-day average, and so on.

At the bottom of each box (as applicable), a trend percentage is shown, with an up or down arrow. Trend values are calculated from the most recent section of the reported data range, to provide insight into any recent changes in how or when the therapies were used.

KEY

Parameter Name

###units
(30-Day Average)

▲ ▼ %
(Last 7 Days Trend)



Days Used
30

Use (of days used) 24 Hours ---	Use (of all days) 24 Hours ---
Vte 437 mL ▲1%	Breath Rate 15 BPM ▼2%
Minute Vol. 6.6 mL ▲1%	MAP 9 cmH2O ▲16%
PIP 26 cmH2O ---	PEEP/EPAP 4 cmH2O ---
Pt. Trigger 98 % ▲2%	Leak 1 L/min ---

Compliance Calendar

The Multi-View compliance calendar provides an overview of how often therapies were used throughout the report range.

Ventilation and Oxygen are shown with a number below representing how many hours these therapies were used each day.



HOURS/DAY

NOTE: V*Home includes only Ventilation and Oxygen therapies. and N icons will not be present in V*Home Multi-View reports.

9/1 V 24 O 24 N 1	9/2 V 24 O 24 N 1	9/3 V 24 O 24 N 1	9/4 V 24 O 24 N 3	9/5 V 24 O 24 N 1	9/6 V 24 O 24 N 1	9/7 V 24 O 24 N 1
9/8 V 24 O 24 N 1	9/9 V 24 O 24 N 1	9/10 V 24 O 24 N 1	9/11 V 24 O 24 N 1	9/12 V 24 O 24 N 1	9/13 V 24 O 24 N 1	9/14 V 24 O 24 N 1
9/15 V 24 O 24 N 1	9/16 V 24 O 24 N 1	9/17 V 24 O 24 N 1	9/18 V 24 O 24 N 1	9/19 V 24 O 24 N 1	9/20 V 24 O 24 N 1	9/21 V 24 O 12 N 1
9/22 V 24 O 12 N 1	9/23 V 24 O 12 N 1	9/24 V 24 O 12 N 1	9/25 V 24 O 12 N 1	9/26 V 24 O 12 N 1	9/27 V 24 O 24 N 1	9/28 V 24 O 24 N 1
9/29 V 24 O 24 N 1	9/30 V 24 O 24 N 1					

Therapy Use

Graphed therapy use provides instant insight into multi-therapy use and trends over time.

These charts also show the time and duration of alarm activations during the reported period. Therapy use charts appear at the tops of pages to provide insight into settings changes and monitor values in the context of the frequency of all therapy uses over the reported period. The gray shaded area indicates the period of time trend values are calculated from.

NOTE: V*Home includes only Ventilation and Oxygen therapies, and Nebulizer compensation.

NOTE: For reports generated from V*Home device software versions 5.00 and later, you may see 'pins' in the therapy use chart, which correspond to Mark Event button presses. For more information on the Mark Event button, see "The Mark Event Button" on page 90.

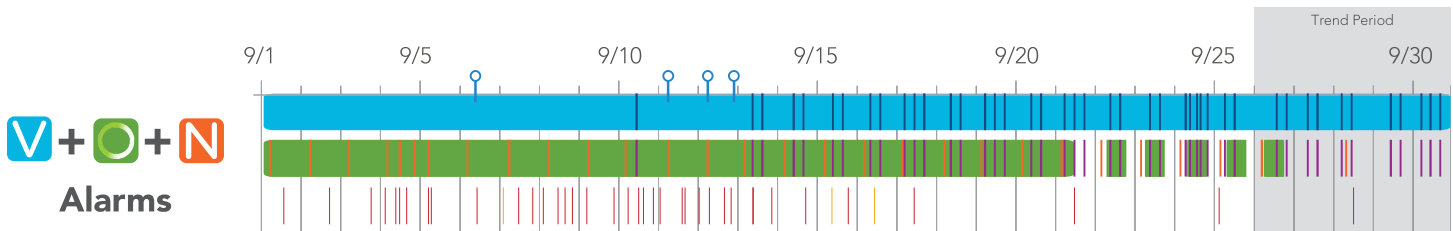

Settings Overview

The settings overview chart provides a visual representation of all V*Home configuration changes.

The settings for the active preset are displayed. Any control changes made over the report duration are graphed on the chart to show when they occurred, and what the setting was changed to.

Ventilation Settings	
Mode	● Bi-Level
Patient Type	● Adult
Humidification	● HME
Circuit Type	● Valveless
Breath Rate	● 12
Backup Rate (BPM)	
Inspiratory Time (seconds)	● 1.0 ● 1.2
Oxygen Settings	
Oxygen Source	● External Low-Pressure
Oxygen Delivery Mode	● Bleed In

Monitor Details

Use the Monitor Details section to view detailed information about changes in delivered therapies over time.

The boxes on the right-hand side of the page identify the monitor (including which therapy it's applicable to: [Ventilation](#), or [Oxygen](#)). It also provides the average monitor value over the report range. Below, the report shows much the monitor increased or decreased during the trend window compared to the rest of the report range. At the bottom, the percentage increase or decrease this trend number represents is displayed.

The gray shading on the graphed portion of the monitor indicates the trend window. The range this window covers depends on what report duration was selected at the time the report was generated.

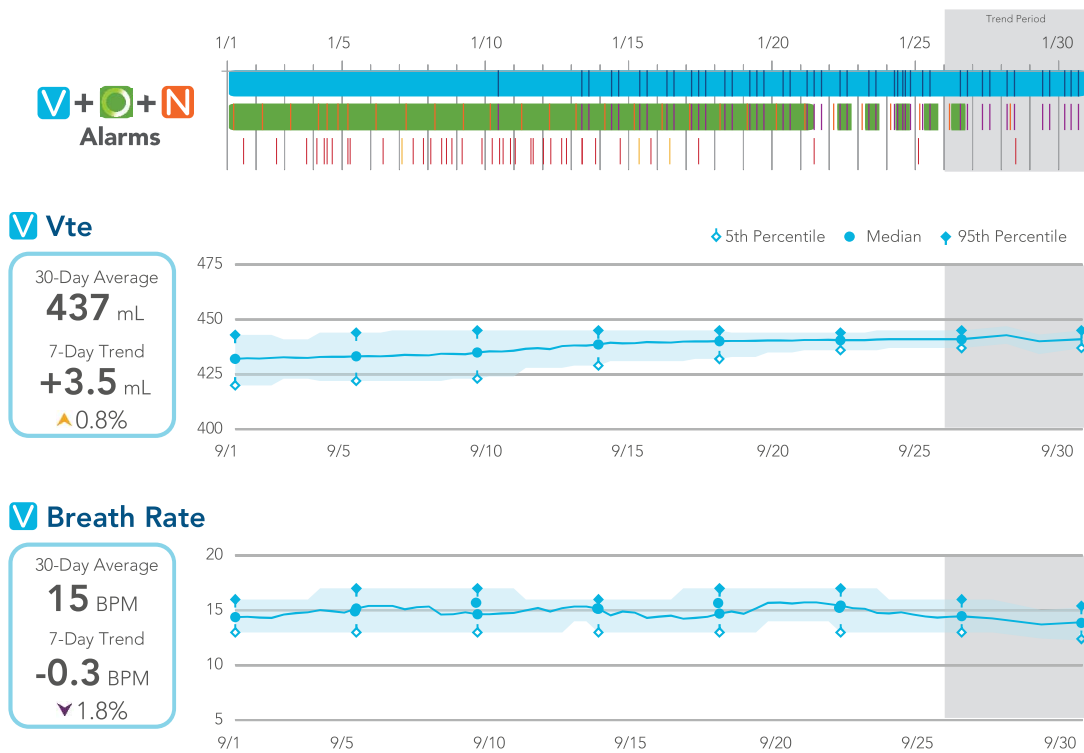

Logs

At the end of the report, you may choose to include detailed logs that include information about every user interaction with the V*Home device over the report period. Multi-View provides four different optional Logs selections when generating a report:

- **Therapy Log** - The Therapy Log details the duration and start/stop times of all delivered V*Home therapies including Ventilation and Oxygen.
- **Alarm Log** - The Alarm Log section shows every alarm activation, with its start/stop time and duration.
- **Configuration Log** - The Configuration Log includes detailed information about all V*Home settings changes made over the report duration. It shows the time of the configuration event, as well as the previous and updated control values. Detailed sub-sections for System, Ventilation, and Oxygen organize this information by therapy.
- **Event Log** - The Event Log is a combination of all three other logs, showing every user interaction with V*Home over the report duration.

NOTE: To prevent generating reports that are too long to be usable, report Logs sections are limited in size.

Checkout Procedure

Ventec Life Systems recommends a series of checks and tests to ensure V*Home is ready to use safely. Perform these tests before using VOCSN for the first time, and periodically during use. See *“Recommended Maintenance Schedule”* on page 131 for the maintenance schedule recommended by Ventec Life Systems.

NOTE: This chapter describes checkout procedures for Ventilation and Oxygen therapies. Test only those therapies that are enabled for use with V*Home.

Visual Inspections

Inspect the exterior of V*Home for signs of damage.

WARNING: Do not use V*Home if it has evident signs of damage. External damage may be an indication of internal damage, and could adversely affect the performance of V*Home. Contact your local Ventec Life Systems representative for service.

Inop Alarm Test

To verify the Inop alarm is functional:

- 1 Each time you power on V*Home, listen for two audio tones. These tones verify the V*Home backup alarm, which is used in case of an Inop alarm condition or an issue with the V*Home speaker.
- 2 If you do not hear two audio tones when powering on V*Home, contact your local Ventec Life Systems representative for service.

Power Testing Procedures

To verify that V*Home power sources are functioning properly:

- 1** Verify that the two removable, rechargeable batteries are properly installed in the V*Home battery wells.
- 2** Plug V*Home into a source of external power, such as a wall outlet.
- 3** With V*Home powered on, verify the following:
 - V*Home operates.
 - The charge status indicator light on the front of V*Home is lit (green or orange).
 - The three battery icons on the V*Home touchscreen display a fully-charged status, or a lightning bolt appears on one of the three battery icons to indicate charging.
 - The external power icon () appears in the status bar.
- 4** Disconnect V*Home from external power and verify:
 - V*Home continues to operate on removable, rechargeable battery power.
 - The medium-priority Battery Use alarm activates.
 - The green external power indicator light on the front of V*Home is not lit.
 - The two removable battery icons on the V*Home touchscreen display the charge status noted in the previous step.

NOTE: The V*Home batteries will not charge when overheated. Battery overheating may occur when V*Home is run at settings that consume maximum power, and/or when it is operated in conditions outside its top environmental temperature range.

- 5** Disconnect the two removable batteries from V*Home and verify:
 - V*Home continues to operate on internal battery power.
 - The green external power indicator light on the front of V*Home is not lit.

NOTE: Periodically verify that the batteries are functional, and that the Internal Battery Low and Internal Battery Critically Low alarms are functional, by disconnecting V*Home from external power until the batteries drain and these alarms activate.

- 6** Reinstall the removable batteries, and plug V*Home into an external source of power. Keep V*Home plugged in until all batteries are fully charged. The charge status indicator light on the front of V*Home will illuminate green when all V*Home batteries are fully charged.

NOTE: Other steps in this checkout procedure may be performed while V*Home batteries are charging.

NOTE: V*Home battery icons on the touchscreen show the charge status of the batteries relative to when they were new. As the batteries age, their capacity will diminish. Ventec Life Systems recommends replacing batteries when they will no longer charge above 50%.

Ventilation Testing Procedures

Connect a passive Ventec One-Circuit, flex tube, and a 1L (one liter) test lung to V*Home to test Ventilation therapy. See *“Setup” on page 16* for configuration instructions. To test V*Home Ventilation therapy, first change the V*Home control settings to those listed in the table below.

NOTE: See *“Changing Ventilation Therapy Settings” on page 60* for configuration instructions.

NOTE: If testing V*Home between patient uses, begin by restoring it to its factory defaults using the [Reset for New Patient](#) control in the [Device Settings](#).

NOTE: If V*Home is in long-term use with a patient, these testing procedures may be performed using the existing V*Home configuration. Periodically verify the monitors and alarms described in this chapter are functioning correctly.

NOTE: Some settings and alarms may not be applicable to a mouthpiece patient circuit setup. Configure and test only those settings and alarms that are available when the Circuit Type control is set to Mouthpiece.

NOTE: When Preset 3 is activated, the below settings will be configured as a default.

Control	Setting
Circuit Type	Passive
Ventilation Mode	AC-Volume
Tidal Volume	400 mL
PEEP	5 cmH ₂ O
Breath Rate	12 BPM
Inspiratory Time	1.7 seconds
Flow Trigger	4 L/min
High Inspiratory Pressure alarm	40 cmH ₂ O

Ventilation Tests

After configuring Ventilation therapy using the settings described in *“Ventilation Testing Procedures”* on page 112, verify the complete the following steps while Ventilation therapy (and Oxygen therapy, if prescribed) is running:

NOTE: For mouthpiece patient circuit setups, these verification steps are not applicable.

NOTE: These ranges represent the combined tolerances of the delivered therapy and their independent monitor.

- 1** Run a Pre-Use Test. See *“Running the Pre-Use Test”* on page 34 for instructions.
- 2** Verify the Vte monitor reads between 279 and 541 mL.
- 3** Verify the PEEP monitor reads between 2 and 8 cmH₂O.
- 4** Verify the Leak monitor reads between 20 and 40 L/min.
- 5** Count the number of breaths delivered over one minute to verify the delivered Breath Rate is 12 BPM.

Ventilation Alarm Verification

To ensure alarms are functioning correctly, maintain the control settings configured as part of “Ventilation Testing Procedures” on page 112.

NOTE: When performed as a maintenance step during patient use, the V*Home alarm system may be performed using existing V*Home control settings.

Follow the procedures in the following pages, and verify the following while testing each alarm:

- The name of the alarm condition appears in the upper left-hand corner of the touchscreen.
- A blue, yellow, or red banner flashes across the top of the touchscreen.
- Audible alarm tones are emitted from V*Home.
- When an alarm deactivates, verify that the flashing blue, yellow, or red banner disappears from the top of the touchscreen, and that the audible alarm tones stop.

Test each alarm as described in the sections below.

NOTE: V*Home tests High PEEP, High Pressure, and High/Low FiO₂ alarms automatically. The Patient Circuit Disconnect and decannulation tests are designed to ensure the Patient Circuit Disconnect and Low Minute Volume alarms are functioning correctly. Activation of the Low Minute Volume alarm serves as verification the High Minute Volume is also functional.

Remote Alarm Test (Optional)

If using V*Home with a remote alarm, verify that it is functioning properly before use:

- 1** Connect the remote alarm to V*Home and follow all testing instructions provided by the remote alarm manufacturer.
- 2** Verify that the remote alarm activates with each of the alarm conditions described in the remainder of this alarm testing procedure.

Decannulation Alarm Verification

If using a Ventec One-Circuit with a tracheostomy tube, you may choose to verify that alarms activate with decannulation before use or periodically during use. Other patient circuit interfaces may also benefit from decannulation alarm verification. Follow your healthcare institution's protocol.

To verify decannulation causes alarms to activate:

- 1 If V*Home is in use with a patient, provide an alternative means of Ventilation therapy to the patient.
- 2 Disconnect the Ventec One-Circuit from the patient's tracheostomy tube or from the test lung.
- 3 With a clean, gloved hand, connect the patient's emergency tracheostomy tube to the Ventec One-Circuit (without a test lung) and verify the appropriate alarms activate (Patient Circuit Disconnect and/or Low Minute Volume and/or Low Inspiratory Pressure).

NOTE: If alarms do not activate during the decannulation alarm verification procedure described, alarm settings may need to be adjusted, or other means of decannulation detection may need to be added to the V*Home system.

- 4 Reconnect the Ventec One-Circuit to the patient tracheostomy tube or test lung.

Patient Circuit Disconnect Alarm Verification

To verify the Patient Circuit Disconnect alarm is functional, follow your healthcare institution's protocol, and:

- 1 If V*Home is in use with a patient, provide an alternative means of Ventilation therapy to the patient.
- 2 Disconnect the Ventec One-Circuit from V*Home at the bacterial filter and verify the appropriate alarms activate (Patient Circuit Disconnect and/or Low Minute Volume and/or Low Inspiratory Pressure).
- 3 Reconnect the Ventec One-Circuit and verify all active alarms deactivate.

Configure and Verify Control and Alarm Settings

Before providing therapy to the patient, set the VOCSN control and alarm settings appropriately for the patient condition, and verify they are correct. See *"Controls and Settings"* on page 59 and *"Alarms"* on page 80 for configuration instructions and a description of available settings.

Verify the [Date](#) and [Time](#) settings are correct. These controls can be found in [Device Settings](#) on the [Menu](#) tab.

Checkout Worksheet

The checkout procedures listed in the following worksheet should be performed before using V*Home on a patient, and periodically during use. Print and complete a copy of this worksheet to verify V*Home checkout procedures were completed.

NOTE: If V*Home is in long-term use with a patient, these testing procedures may be performed using the existing V*Home configuration. Periodically verify the monitors and alarms described in this chapter are functioning correctly.

Function	Settings	Requirement	Pass / Fail / NA
Visual Inspection	N/A	No part of the device or connected components appear damaged	
Inop alarm	N/A	Two audible tones sound at V*Home power up	
Power	N/A	VOCSN functions on external, removable battery, and internal battery power	
Ventilation	Ventilation Mode: AC-Volume Tidal Volume: 400 mL PEEP: 5 cmH2O Breath Rate: 12 BPM Inspiratory Time: 1.7 seconds Flow Trigger: 4 L/min	The Vte monitor reads between 279 and 541 mL	
		The Leak monitor reads between 20 and 40 L/min	
		The PEEP monitor reads between 2 and 8 cmH2O	
		The delivered Breath Rate is 12 BPM	
		There are no active alarms	
Alarms	Maintain settings configured as part of Ventilation checkout procedure.	Decannulation causes Patient Circuit Disconnect and/or Low Minute Volume alarm to activate as expected	
		Disconnecting the Ventec One-Circuit causes Patient Circuit Disconnect and/or Low Minute Volume alarm to activate as expected	
		Remote alarm activates as expected (optional)	

V*Home Serial Number: _____

Tester Name: _____ Date: _____

Signature: _____

Operating Instructions

This chapter describes how to start and use V*Home therapies. See *“Controls and Settings” on page 59* for therapy configuration instructions

WARNING: When in use for a prolonged period at its maximum environmental operating temperature, V*Home may reach a temperature at the patient connection port of 43°C. To ensure patient safety, avoid prolonged use at maximum operating temperatures, and move the patient and the device to a cooler location if necessary. Use of V*Home outside its recommended range of temperature, altitude, and/or relative humidity may adversely affect the ventilation and oxygen concentration flow rate from V*Home, and may result in patient harm. See *“Environmental” on page 153* for details.

WARNING: If critical to patient care, always have an alternative means of ventilation and oxygen available. In case of unexpected V*Home operation, failure to have alternative means of therapy available may result in patient harm or death.

WARNING: Do not use V*Home within magnetic resonance (MR) environments. Using V*Home within MR environments may affect V*Home or MR device performance, damage the devices, or harm individuals.

WARNING: If the patient feels discomfort or experiences a medical emergency during Ventilation or Oxygen therapy, seek medical assistance immediately. Patients unable to communicate discomfort (such as geriatric or pediatric patients) may require additional monitoring and/or a distributed alarm system to alert the caregiver to the discomfort and ensure patient safety.

Powering On V*Home

V*Home will run on external power (such as a wall outlet), or on its internal and removable batteries. Ventec Life Systems recommends powering V*Home with an external, continuous source of power whenever possible. See *“Power Setup” on page 18* for instructions on connecting V*Home to external power.

NOTE: After pressing the On/Off button, V*Home will be ready to deliver therapy in ≤ 30 seconds.

- 1 Press the On/Off button on the front of V*Home to power on the device.

NOTE: If V*Home is in Battery Storage Mode, external power must be connected to activate the batteries and power on the device. See *“Battery Storage Mode” on page 133* for more information.

- 2 Verify the state of all power sources before initiating therapy:

- If V*Home is connected to external power, the power connection icon appears on the touchscreen, and the charge status indicator light on the front of V*Home is illuminated.
- The two removable batteries are adequately charged, or charging.
- The internal battery is fully charged.

- 3 Check the V*Home Date and Time settings, and adjust them if needed. See *“Changing Device Settings” on page 78*. for instructions.

If the internal battery depletes fully, V*Home Date and Time settings will reset to their default values. To ensure the Alarm and Event logs record information accurately, verify the V*Home Date and Time settings before use, and set them to the correct values if necessary.



Starting V*Home Therapies

Although patients may be intended V*Home operators for some functions, patients should not configure or initiate Ventilation or Oxygen therapy without supervision. Once configured by a clinician, some patients may be able to safely switch between Ventilation therapy Presets.

It is of vital importance that a caregiver or other supervisor capable of responding to any V*Home alarms be present during V*Home therapy. The V*Home clinician or caregiver must be capable of responding to alarm conditions, and trained to use V*Home. A list of available V*Home training options is available at VentecLife.com.

To ensure the delivered therapy is adequate, monitor the patient each time V*Home is started, control settings are modified, an accessory is attached, or the Ventec One-Circuit is reconfigured. The operator of V*Home should be within range of the audible V*Home alarm tones. Place V*Home so that any monitors critical to patient care are visible.

WARNING: Do not use V*Home with helium (including mixtures with helium), nitric oxide, or in a hyperbaric chamber. V*Home has not been validated for safe use with helium, nitric oxide, or for use in a hyperbaric chamber.

NOTE: If V*Home performs unexpectedly, prepare an alternate means of ventilation, monitor the patient, and contact your local Ventec Life Systems representative for service.

Starting Ventilation Therapy

To begin Ventilation therapy using V*Home, first ensure the Ventec One-Circuit is correctly configured, and all Ventilation therapy controls and alarms are set appropriately for the patient condition.

NOTE: If a speaking valve is used, Ventec Life Systems recommends use of an active Ventec One-Circuit and/or pressure mode of ventilation. See *“Setting up Ventilation Therapy with a Speaking Valve”* on page 29 for more information.

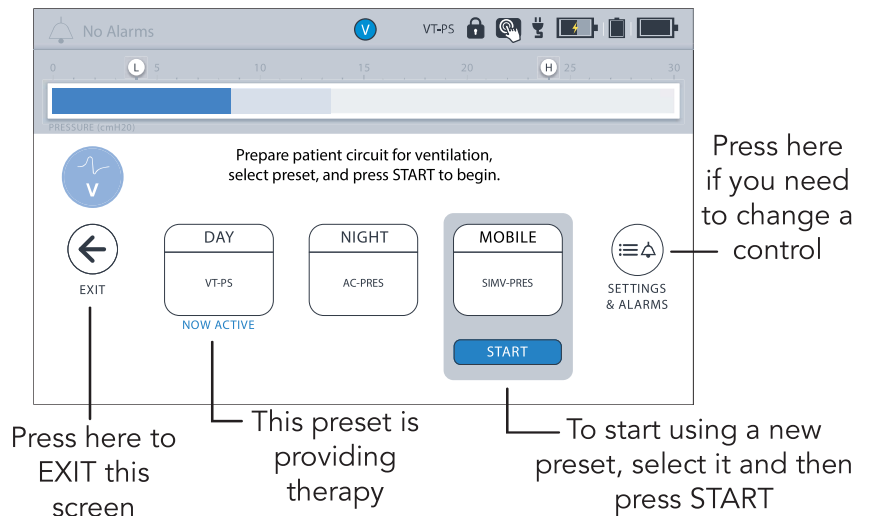

WARNING: Always have a backup means of ventilation available (such as a backup ventilator or manual resuscitator) in case of V*Home failure. Inability to immediately access an appropriate alternative means of ventilation may result in death for patients dependent on Ventilation therapy.

To begin ventilation therapy:

- 1 Connect the Ventec One-Circuit and any patient circuit components. See *“Connecting a Passive or Valveless Ventec One-Circuit”* on page 23 for instructions.
- 2 Press the On/Off button.
- 3 Verify that the set Ventilation therapy controls and alarms are set correctly, and that the correct Ventilation therapy Preset is active.

NOTE: To verify or change Ventilation therapy settings, press the EXIT button on the Pre-Use Test screen. Follow the instructions described in *“Changing Ventilation Therapy Settings”* on page 60.

- 4 Run the Pre-Use Test.

NOTE: If the Pre-Use Test screen does not appear automatically, run a user-initiated Pre-Use Test by pressing the Menu tab, and then the PRE-USE TEST button.

NOTE: If used, remove the HME from the Ventec One-Circuit to ensure the Pre-Use Test passes and correctly calculates the Ventec One-Circuit resistance.

- 5 Ventilation therapy will begin. For information about monitored Ventilation therapy parameters, see *“Ventilation Monitors”* on page 95.

Changing Between Configured Ventilation Presets

V*Home can be configured with up to three different Ventilation therapy Presets. To begin Ventilation therapy using a different Preset:

- 1** Press the **Therapy** tab, and then press the **Ventilation** therapy icon.
- 2** Press the name of the Preset you want to activate.
- 3** Press **START** on the bottom of the screen to begin Ventilation therapy using the selected Preset control and alarm settings.

NOTE: If the Circuit Type control of the selected ventilation Preset is set to a value different than the existing Preset, you will be prompted to modify the Ventec One-Circuit accordingly and run a Pre-Use Test prior to reinitializing Ventilation therapy. If time constraints make running the test inadvisable, press the **EXIT** button to immediately initiate Ventilation therapy with the selected Preset.

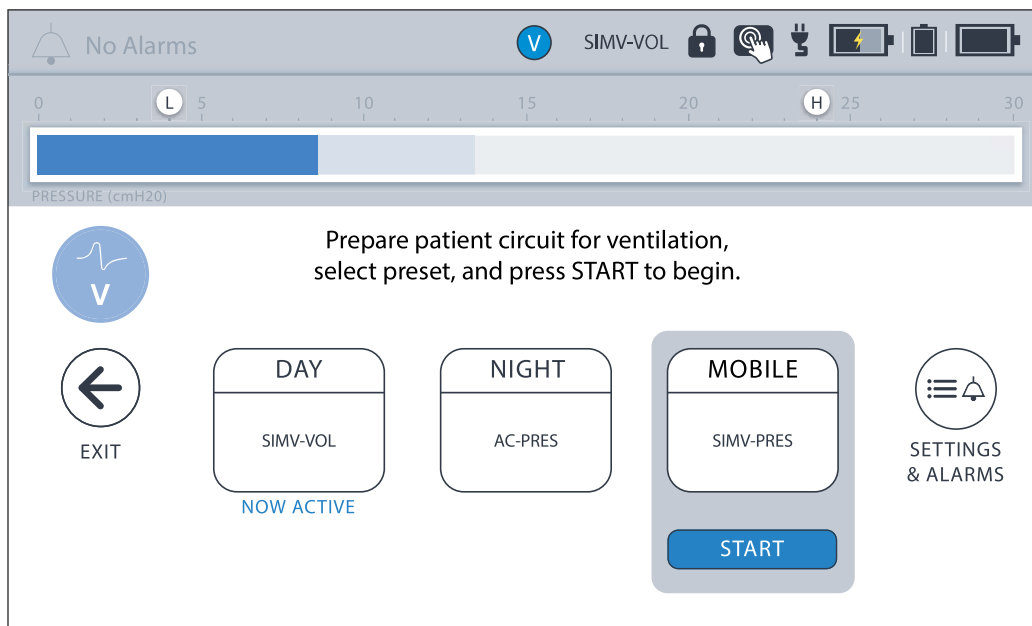

NOTE: To change Ventilation therapy settings press the Preset name and then the **SETTINGS & ALARMS** button. Follow the instructions described in *“Changing Ventilation Therapy Settings”* on page 59 to modify Ventilation therapy settings. When configuration is complete, press **< EXIT** to return to the Ventilation therapy screen.

Starting Oxygen Therapy

V*Home can provide oxygen therapy using a low pressure oxygen source. To configure Oxygen therapy presets, select a preset and then press the **SETTINGS & ALARMS** button. Use the blue **START** button to activate an oxygen preset.

NOTE: Oxygen therapy can be hazardous to patients with certain medical conditions. Always seek professional medical advice before using V*Home to provide oxygen therapy to a patient

WARNING: Do not smoke near elevated oxygen levels. Smoking near elevated oxygen levels greatly increases the risk of fire, and may result in facial burns or death. Do not smoke in the same room as, or produce open flames within 2 meters of, a running oxygen concentrator or other oxygen sources or accessories that are in use. Leave the room containing the oxygen source if smoking.

WARNING: Do not bleed oxygen into the Ventec One-Circuit from an external source not connected to one of the VOCSN oxygen input ports. Bleeding oxygen directly into the Ventec One-Circuit may increase the patient's tidal volume, or affect breath triggering.

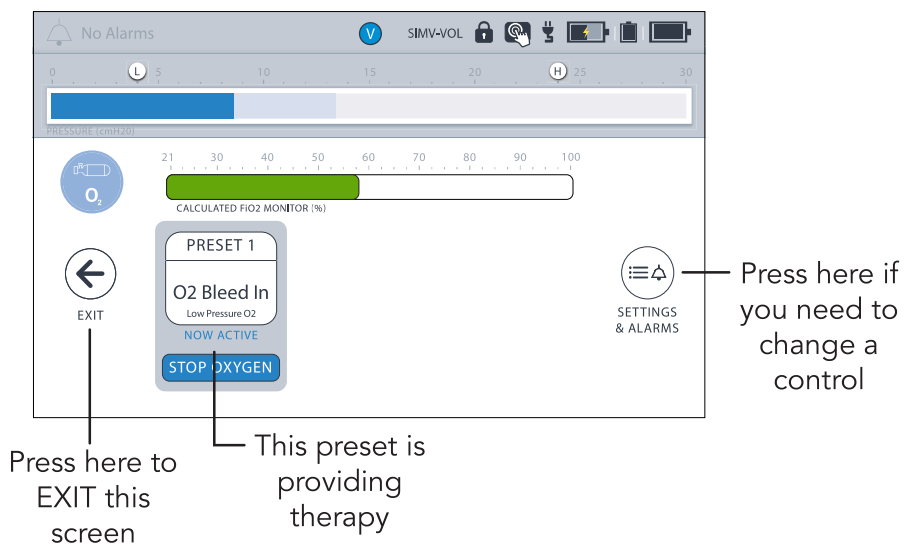

Starting Nebulizer Compensation

V*Home can be configured to compensate for the flow added to the patient circuit from an external 6 L/min nebulizer.

NOTE: Variations in the characteristics of nebulizer cups can affect the accuracy of delivered Tidal Volumes during ventilation, particularly for patients with inspiratory flows <15 L/min. When starting patients on Nebulizer therapy, verify they are receiving adequate ventilation before leaving them unattended.

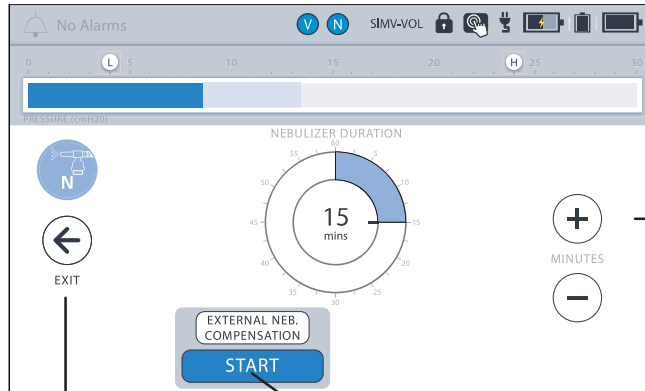

Press here to EXIT this screen

Press here to select external nebulizer compensation

Press here to increase or decrease how long the nebulizer runs

NOTE: If Oxygen therapy is critical to patient care, it is important to understand the effect of External Nebulizer Compensation on oxygenation, particularly for patients receiving small Tidal Volumes. For a detailed description of the External Nebulizer Compensation feature, including recommendations for maintaining the intended patient oxygenation, see *"External Nebulizer Compensation"* on page 174.

NOTE: To ensure proper device operation, all nebulizer parts connected to V*Home should comply with the relevant requirements of ISO 27427.

CAUTION: V*Home Nebulizer therapy is not recommended during High Flow therapy for pediatric patients receiving <15 L/min. At Flow settings of <15 L/min, the accuracy of the delivered flow may be affected by Nebulizer therapy. While not recommended, Flow settings of 4 or 5 L/min will display as 6 L/min during Nebulizer therapy (and may not accurately represent the actual flow delivered) because of added flow through the nebulizer.

WARNING: Use only 6 L/min nebulizer cups with V*Home. V*Home ventilation compensates for 5.9 L/min of nebulizer flow. When gas is added to the Ventec One-Circuit from a nebulizer producing a flow less or more than 6 L/min, the accuracy of delivered ventilation may be temporarily affected.

Responding to Alarms

The V*Home operator must be capable of responding to alarm conditions and promptly performing the necessary corrective actions. See *“Alarm Silence Button” on page 81* for information on each alarm condition. In case of V*Home malfunction, the operator must be able to promptly provide an alternative means of ventilation.

Powering Off V*Home

To power off V*Home, press and hold the On/Off button for at least three seconds. Release the button and then press OK on the touchscreen to confirm and power off V*Home.

If the V*Home touchscreen is not accessible, you may also press and hold the On/Off button for at least ten seconds. A pop-up will appear while the backup alarm sounds and the Alarm Silence button flashes. Within 10 seconds, press and hold the Alarm Silence button until the V*Home touchscreen indicates the device is shutting down.

Cleaning and Maintenance

The organization responsible for the use and maintenance of V*Home should perform all adjustments, cleaning, and disinfection of V*Home. Follow all instructions provided in this Clinical and Technical manual to prevent damage to V*Home during cleaning and maintenance procedures.

NOTE: All V*Home single-patient use components and Ventec One-Circuits are not intended for cleaning, sterilization, or re-use. Replace V*Home single-patient use components and Ventec One-Circuits regularly, following your healthcare institution's protocol.

Cleaning V*Home

Before cleaning any part of V*Home, disconnect external power sources.

WARNING: Do not perform maintenance or service on V*Home while it is powered on or in use. Maintenance, or service procedures performed during use may temporarily alter the performance of V*Home and result in patient harm.

WARNING: Do not touch the patient and parts inside the V*Home enclosure simultaneously. High flows of electricity are present inside V*Home enclosure and may be an electrocution hazard.

WARNING: Do not use ozone or any other non-approved cleaning materials on any part of V*Home, or exceed its recommended storage temperature or humidity ranges to disinfect it.

Cleaning V*Home Exterior

Clean the exterior of V*Home every three months during use, between patient uses, or as needed if exposed to contaminants.

1 Unplug V*Home from any connected external power sources. Ozone, abrasive cleaners and materials may damage the casing or display. Use only cleaning materials recommended in this manual. Clean the entire exterior surface with one of the following wipes or solutions with a soft cloth:

- Solutions: Water (including water mixed with soap or a mild detergent), 70% isopropyl alcohol, MadaCide FD, Metrex CaviCide1
- Wipes: MadaCide FDW, Metrex CaviWipes, PDI Super Sani-Cloth, PDI Sani-Cloth Plus, Diversey Oxivir, or Safetec SaniZide Plus

NOTE: Pay close attention to the LCD screen while cleaning, to ensure buttons on the touchscreen are not unintentionally pressed. Ventec recommends locking the touchscreen using the lock screen button in the status bar, and then gently wiping over the top of and across the touchscreen to clean it. This technique helps prevent inadvertent button presses.



2 Do not allow liquid to drip through V*Home exterior casing or into the removable battery well. Use a soft, dry cloth to remove any residual moisture after cleaning.

3 Visually inspect V*Home to verify it is clean. Repeat the cleaning steps described above until V*Home passes a visual inspection.

4 Let V*Home dry completely after cleaning before plugging it in to an external power source.

Cleaning the Air and Fan Filters

Clean the air and fan filters every two weeks to ensure V*Home internal components are protected from dirt and dust. Replace the filters every six months, or as needed due to damage.

- 1** Power off and unplug V*Home.
- 2** Remove the air and fan filters.
- 3** Inspect the air and fan filters for dirt or damage.
- 4** Wash the air and fan filters using warm water and soap or a mild detergent.
- 5** Rinse the filters thoroughly under running water to remove all soap or detergent residue.
- 6** Place the filters on a clean surface and allow them to dry completely.

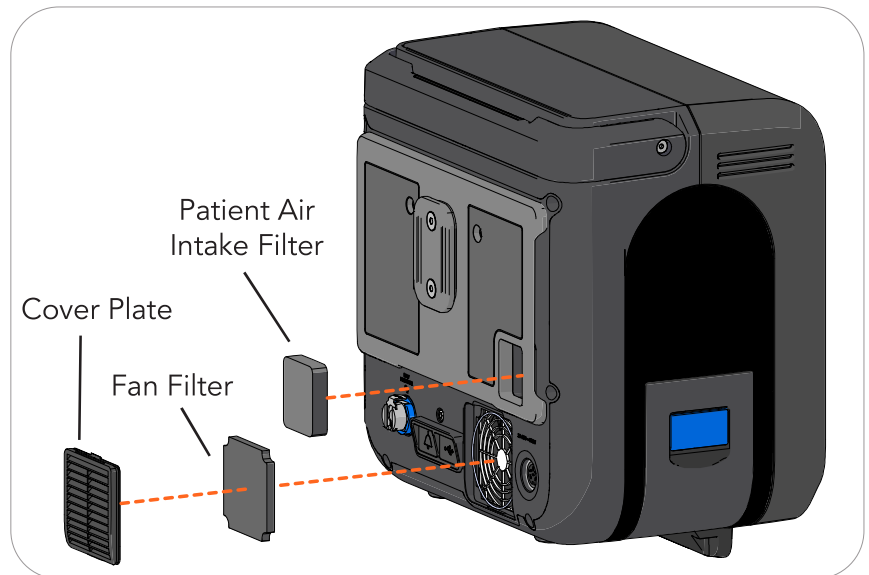

- 7** Inspect the filters for signs of damage or contamination. Replace the filters if they appear damaged. Repeat the cleaning steps described above until the filters pass a visual inspection for cleanliness.

NOTE: Replacement air filters are available from Ventec Life Systems.

- 8** Reinstall the air and fan filters. Reinstall cover plate with slats on cover facing down.

NOTE: Check to ensure the black o-ring is installed around the exterior of the fan filter cover grate.

Replacing Components

Replacing the Power Supply

For a replacement power supply, contact Ventec Life Systems service representative. To replace the V*Home AC adapter, unplug the AC adapter from the outlet and the V*Home, and dispose of it in accordance with local regulations.

Connect the new AC adapter to the V*Home and power outlet. For more information, see *"Power Setup"* on page 18.

Replacing the Ventec One-Circuit

Ventec One-Circuits are intended for single-patient use. Replace the Ventec One-Circuit between patient uses, or whenever it becomes contaminated.

The patient condition, damage to the Ventec One-Circuit, or contamination may be conditions that require Ventec One-Circuit replacement. Follow your healthcare institution's protocol for Ventec One-Circuit replacement criteria.

NOTE: Replacement parts are available from Ventec Life Systems. Contact your Ventec Life Systems representative to order a replacement Ventec One-Circuit. See *"Accessories"* on page 162 for a list of accessories available from Ventec Life Systems.

To replace a Ventec One-Circuit:

- 1 Provide an alternate means of ventilation, if required, and power off V*Home.
- 2 Disconnect the Ventec One-Circuit from V*Home. Disconnect all Ventec One-Circuit components.
- 3 Connect a new Ventec One-Circuit and reconnect all components. See *"Connecting a Passive or Valveless Ventec One-Circuit"* on page 23 for instructions.
- 4 Power on V*Home by pressing the On/Off button.
- 5 Run a Pre-Use test. See *"Running the Pre-Use Test"* on page 34 for more information.
- 6 Resume V*Home Ventilation therapy.

Replacing Ventec One-Circuit Components

Follow your healthcare institution’s protocol for cleaning and replacement of Ventec One-Circuit components, as well as any instructions and recommendations for replacement provided by Ventec One-Circuit accessory manufacturers. Inspect all accessories including your humidifier or HME, nebulizer, external bacterial filter, and any other accessories for signs of damage. Discontinue use and replace any damaged Ventec One-Circuit accessories immediately.

NOTE: Ventec Life Systems recommends running a Pre-Use Test each time the Ventec One-Circuit configuration is modified. See *“Running the Pre-Use Test”* on page 34 for instructions.

Replacing the External Bacterial Filter

The external bacterial filter is intended for single-patient use. Replace the external bacterial filter between patient uses, whenever it becomes soiled or damaged, or every 30 days (at a minimum). Follow your healthcare institution’s protocol for replacement criteria.

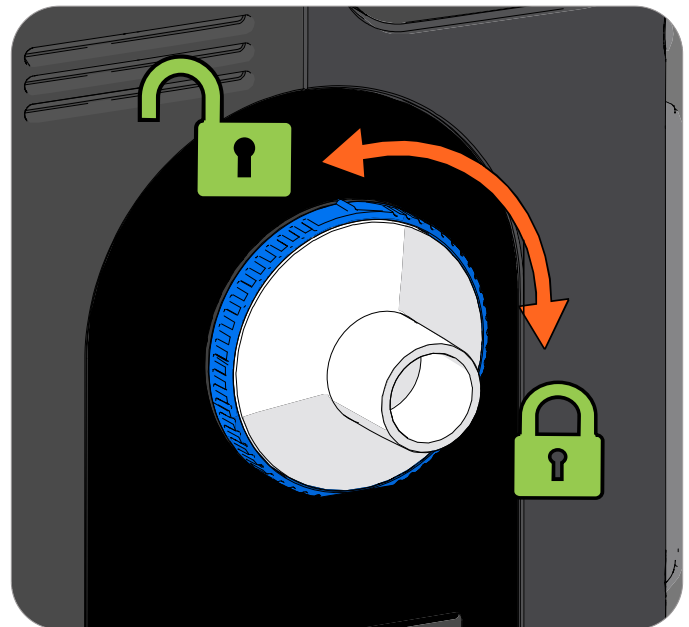
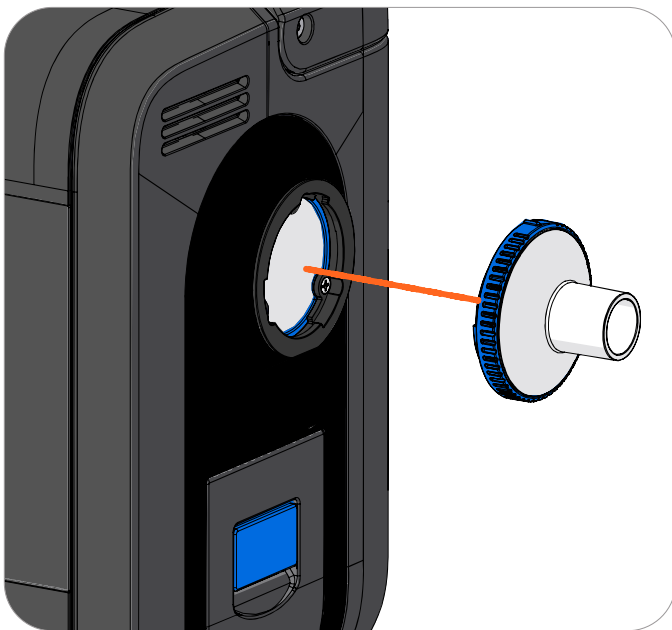

Replacing the Internal Bacterial Filter

Replace the V*Home internal bacterial filter whenever it may have become contaminated or the external bacterial filter is compromised.

NOTE: It may be necessary to replace the internal bacterial filter more often in some environments, such as those with cigarette smoke. V*Home may fail its Pre-Use Test if the internal bacterial filter becomes heavily contaminated.

To remove and replace the Internal Bacterial Filter:

- 1 If needed, provide the patient with backup ventilation, and then remove the patient circuit and the external bacterial filter. See *"Replacing the External Bacterial Filter"* on page 129 for detailed instructions.
- 2 Using a #1 Phillips torque driver, remove the 3 screws in the mounting ring, which holds the filter in place. Then, remove the mounting ring.
- 3 Pull the Internal Bacterial Filter out, and replace it with a new one.
- 4 Replace the mounting ring and 3 screws, using a #1 Phillips torque driver calibrated to 3 in-lb (48 in-oz).

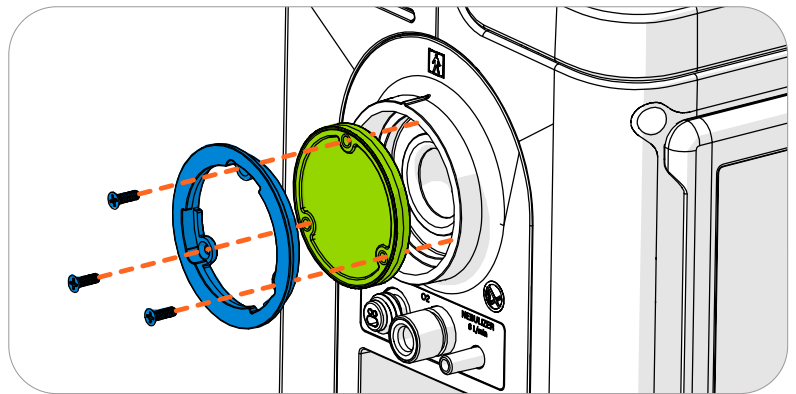

CAUTION: Do not let anything enter the cavity behind the filter during the replacement process. Do not re-install the Internal Bacterial Filter screws without using a calibrated torque driver. Foreign material inside V*Home or using too much torque on these screws may severely damage V*Home.

- 5 Confirm the Internal Bacterial Filter was replaced correctly by performing the *"Ventilation Testing Procedures"* on page 112.

Recommended Maintenance Schedule

Perform V*Home maintenance tasks in the following table at the recommended intervals.

NOTE: V*Home includes an internal clock that monitors the time elapsed since the device was last serviced. The Sys. PM Due In monitor counts down to the next time periodic maintenance should be performed on V*Home by an authorized service representative. Contact your V*Home representative when the Maintenance Due alarm activates.

NOTE: A service manual containing detailed technical information required by authorized service technicians to repair and replace serviceable parts of V*Home is available from Ventec Life Systems on request. Only authorized service technicians should repair V*Home.

Periodicity	Maintenance	May be performed by...
Before storage	Fully charge removable and internal batteries. With software versions 4.11R and later, activate Battery Storage Mode by following the instructions in <i>"Battery Storage Mode"</i> on page 133.	Patient, Caregiver, or Clinician
Every 12 months (in Battery Storage Mode), or every 30 days (active batteries)	Fully charge removable and internal batteries.	Patient, Caregiver, or Clinician
Before each patient use	Run a Pre-Use Test. Fully charge removable and internal batteries. Perform Checkout Procedures. See <i>"Checkout Procedure"</i> on page 110 for instructions. Clean the exterior of V*Home, See <i>"Cleaning V*Home Exterior"</i> on page 126 for instructions.	Caregiver or Clinician
Every day during use	Inspect and clean the air and fan filters. Replace the filters as needed. Inspect the V*Home exterior, including all connection ports and connected components, for signs of damage.	Caregiver or Clinician
Every month during use	Test the V*Home alarm system. See <i>"Ventilation Alarm Verification"</i> on page 114 for instructions. Test the V*Home batteries and power cord. See <i>"Power Testing Procedures"</i> on page 111 for instructions. Replace the V*Home Bacterial Filter.	Caregiver or Clinician
Every three months during use	Clean the exterior of V*Home. See <i>"Cleaning V*Home Exterior"</i> on page 126 for instructions.	Caregiver or Clinician
Every two years, or every 10,000 hours	Contact Ventec Life Systems to have V*Home serviced by a trained technician.	Caregiver or Clinician

Battery Care, Maintenance, and Replacement

The V*Home removable and internal batteries are Lithium-ion. To maximize battery life, charge the V*Home batteries before they drain completely. The batteries charge whenever V*Home is plugged into an external source of power.

Battery icons in the status bar display a battery's charge status relative to its capacity (which diminishes over time). When plugged into external power for an extended period, these status bar indicators will always report a 100% charge, even when the absolute battery capacity has decreased with use and time.

The battery Absolute Charge status (shown on the My VOCSN screen) reports how the battery capacity is diminishing over time. Over time, the battery icons in the status bar will display a full (100%) charge, and the absolute charge status displayed on the My VOCSN screen will read <100%, even when V*Home is plugged into external power for an extended period.

Battery replacement is recommended when the battery icons in the status bar show 100%, but the battery Absolute Charge status on the My VOCSN screen shows 50% or less. This means the battery has half (or less) of the charge capacity it did when new. Removable battery replacements are available from Ventec Life Systems. The internal battery must be replaced by Ventec Life Systems service personnel.

NOTE: Ensure the batteries are fully charged before storing V*Home.

NOTE: The removable batteries are intended to charge while installed in V*Home or the Removable Battery Quick Charger. Do not attempt to charge the V*Home batteries while removed from the V*Home or the charger.

NOTE: Use batteries from Ventec Life Systems. Do not use batteries from other manufacturers to power V*Home.

WARNING: Do not damage the rechargeable Lithium-ion battery. A damaged battery may cause an explosion or fire, and may result in personal injury and/or property damage. To prevent injury or damage:

- Do not use or charge the battery if it appears to be damaged. Signs of damage include, but are not limited to, discoloration, warping, and leaking battery fluid.
- Do not expose the battery to fire, high temperature.
- Do not immerse the battery in water.
- Do not use or store the battery inside a vehicle during hot weather.
- Do not drop or puncture the battery.
- Do not open the battery or short-circuit its contacts.

WARNING: Avoid contact with the rechargeable lithium-ion battery if it appears to be leaking. Battery fluid is corrosive. Contact with battery fluid can result in personal injury and/or property damage. To prevent injury or damage:

- If the battery leaks, avoid contact with the battery fluid.
- If the battery fluid gets into your eyes, immediately rinse your eyes with clean water and seek medical attention. Do not rub your eyes.
- If battery fluid gets onto your skin or clothing, immediately use clean water to wash off the battery fluid.

Battery Storage Mode

V*Home is shipped in Battery Storage Mode to preserve the charge of its three batteries. With software versions 4.11R and later, users can select the Activate Battery Storage Mode control in the Device Settings and place the fully charged internal battery and both removable, rechargeable batteries back into this power-saving storage mode. This allows V*Home to remain in storage for 12 months at a time between recharging the batteries.

IMPORTANT NOTE: If Battery Storage mode is **not** used, all three V*Home batteries should be fully charged every 30 days.

To activate Battery Storage Mode before putting V*Home into storage:

- 1** Fully charge the internal and two removable, rechargeable batteries. The small indicator light next to the On/Off button will illuminate green when all three batteries are fully charged.
- 2** Press the **Menu** tab, and then select **Device Settings**.
- 3** Scroll down the to **Activate Battery Storage Mode** control. Press the control name to highlight it, and then select **Edit**.
- 4** An instructional screen will appear. Follow all on-screen instructions carefully. Ensure both removable, rechargeable batteries are connected, and that external power is disconnected.
- 5** Press and hold the **On/Off** button for 3 seconds (but less than 10 seconds).
- 6** Press **OK** in the pop-up. V*Home will power down, and the Inop alarm will sound to confirm Battery Storage Mode was successfully activated.
- 7** Press the **On/Off** button to clear the alarm.

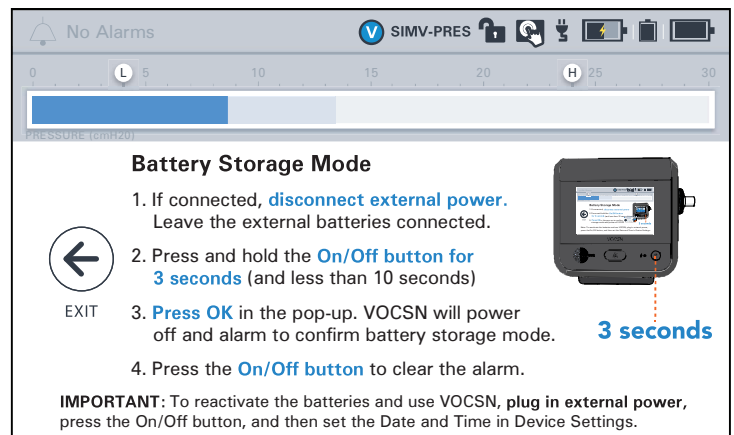

To reactivate the three batteries and use V*Home:

- 1** Leave the removable, rechargeable batteries connected.
- 2** Connect external power. V*Home will immediately power on and sound the Inop alarm to confirm the batteries are active and no longer in storage mode.
- 3** Press the **On/Off** button to clear the alarm.
- 4** Press the **Menu** tab, and then select **Device Settings**.
- 5** Set the **Date** and **Time** controls.
- 6** Follow your healthcare institution's protocol to begin using V*Home.

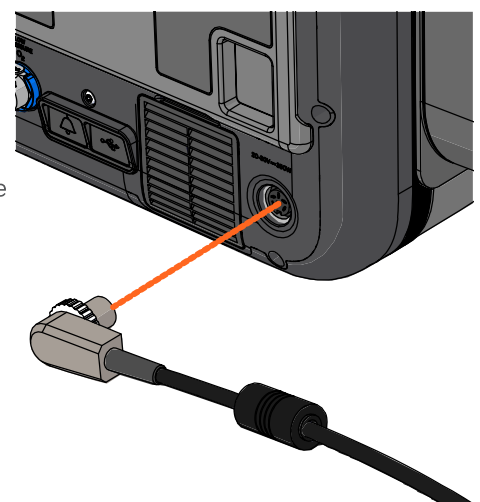

Software Updates

Ventec Life Systems periodically releases V*Home software updates, which may include new features and extended functionality. Software updates occur in the field as needed, or when V*Home is serviced. Contact Ventec Life Systems for additional information about software releases and upgrades.

This Clinical and Technical manual describes the features available with the latest version of software. V*Home devices operating using a previous revision may not include all features and controls described in this manual. The following table provides a high-level overview of the major features released with each software version (listed newest to oldest).

SW Version	Features
5.03	<ul style="list-style-type: none"> Introduced "FiO₂ Control" function on the Quick View menu (Only available for V+C Pro and V Pro configurations) Note: The change to the UI does not impact or change the delivery of External High Pressure Oxygen therapy <ul style="list-style-type: none"> Improved ease of access to change the FiO₂ settings related to External High Pressure Oxygen Therapy Improved ease of access to change the High and Low FiO₂ alarms related to External High Pressure Oxygen Therapy
5.02R	<ul style="list-style-type: none"> Added support for V*Home configuration

Locating the V*Home Software Version

To view which version of software is installed on V*Home:

- 1 Press the [Menu](#) tab.
- 2 Press the [MY VOCSN](#) button.
- 3 Scroll past the [SOFTWARE](#) banner and locate the line item for [UIM SW VERSION](#).



NOTE: In V*Home documentation, software after 4.02 is referred to by the first digit and decimal. For instance, version 4.03.02R is known as 4.03R.

Environmental Considerations

To minimize the environmental impact of V*Home use during its service life, follow all setup, operation, cleaning, and maintenance instructions and recommendations provided in this manual.

V*Home contains lithium-ion (Li-Ion) batteries and other potentially biohazardous materials. Dispose of V*Home and any potentially biohazardous parts or accessories in accordance with local regulations.

Follow your local governing ordinances for disposal and recycling of the Li-ion Battery Pack and its accessories. If Waste Electrical and Electronic Equipment (WEEE) directive regulations apply, do not dispose of the battery in unsorted municipal waste. Within Europe, contact the EU Authorized Representative for disposal instructions. The battery contains Lithium Ion cells and should be recycled. The battery must not be incinerated.

Shipping Considerations





To ensure the device is not damaged during shipment, and that the shipment meets all applicable regulations, always use packaging approved by Ventec Life Systems when shipping V*Home. Contact Ventec Life Systems with questions, and to obtain packaging materials.

Do not ship batteries with signs of mechanical damage by aircraft. Damaged batteries should be discarded or recycled in accordance with local regulations.

Glossary



Glossary of Symbols

The following symbols appear on the exterior of V*Home.

Symbol	Description	Title and Reference
	Consult accompanying product instructions	Refer to Instruction Manual/Booklet ISO 7010 Symbol M002
	Do not operate near open flame	No Open Flame ISO 7010 Symbol P003
	Do not smoke near equipment	No Smoking ISO 7010 Symbol P002
	Do not use the V*Home within magnetic resonance (MR) environments	MR Unsafe ASTM F2503 Table 2
	USB Port	USB 2.0 Port USB Implementers Forum, Inc.





Symbol	Description	Title and Reference
	Indicates the device serial number	Serial Number ISO 7000 Symbol 2498
	Device identifier	Catalogue Number ISO 7000 Symbol 2493
	Authorized European Representative	Authorized European Representative ISO15223-1 Clause 5.1.2
	Environmental requirements for storage and shipping	Temperature Limitation ISO 7000 Symbol 0632
	Dispose of equipment in accordance with requirements of the Waste in Electrical and Electronic Equipment Directive (2002/96/EC)	Recycle: Electronic Equipment EN 50419
	Lithium-Ion battery. Recycle in accordance with local regulations	Li-Ion Battery Recyclable Symbol ISO 7000 Symbol 1135
	On/Off button	Standby IEC 60417 Symbol 5009
	Alarm Silence button	Bell Cancel (Audio Pause) IEC 60417 Symbol 5576-2

Symbol	Description	Title and Reference
	Remote alarm port	Bell IEC 60417 Symbol 5013
	Date of manufacture	Date of Manufacture ISO 7000 Symbol 2497
	Date of Expiry (Expiration). Do not use device after this date.	Use by Date ISO 7000 Symbol 2607
	Name and address of device manufacturer	Manufacturer ISO 7000 Symbol 3082
	Caution	Caution ISO 7000 Symbol 0434A
	Compliant with RoHS (Restriction of Hazardous Substances) Directive	RoHS Compliant RoHS Directive 2002/95/EC
	The V*Home isolates the patient from live voltage in the device	Type BF Applied Part IEC 60417 Symbol 5333
	Indicates external power and battery charging status	External Power Indicator Light Industry standard





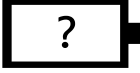

Symbol	Description	Title and Reference
IP32	The IP32 rating indicates that the V*Home enclosure protects it against ingress from wires and tools >2.5mm, and dripping water	Degree of Ingress Protection Provided by Enclosure IEC 60601-1, Table D.3, Symbol 2
Rx ONLY	Federal law restricts this device to sale by or on the order of a physician	Prescription Only 21 CFR 801.15(c)(1)(i)F
	Indicates that the V*Home has been certified by TUV for safety according to Canadian and US regulations	TUV Certification Mark TUV SUD
	Compliant with the requirements of applicable European Union Directives	CE Mark MDD Directive 93/42/EEC

Glossary of Indicators

The following icons and indicators may appear on the VOCSN touchscreen:

Indicator	Description	Indicator	Description
	External battery is fully charged		External battery is more than half depleted
	External battery is charging		External battery is empty or not installed in V*Home
	External battery is not installed in V*Home		External battery status is unknown

Indicator	Description	Indicator	Description
	Internal battery is fully charged		Internal battery is half depleted
	Internal battery is charging		Internal battery is low
	Internal battery is critically low		Internal battery is not installed or its status is unknown.
	This icon appears when external power is connected to V*Home		Toggle. press or slide to toggle between two selections such as On/Off
	Alarm, Low		Alarm, High
	V*Home is locked; Clinician Access Passcode is required to access locked V*Home controls		V*Home is unlocked; Clinician Access Passcode has been entered or is not required, and all V*Home controls are configurable
	Alarm indicator. This icon will appear light gray if there are no alarms, and dark gray if alarms have activated recently. Press the icon to navigate to the Alarm Log.		Alarm is silenced. Press the icon to navigate to the Alarm Log.

Indicator	Description	Indicator	Description
	Touchscreen is unlocked. Press and hold icon for 3 seconds to lock the V*Home touchscreen.		Touchscreen is locked. Press and hold icon for 3 seconds to unlock the V*Home touchscreen.
	The Ventilation icon with a blue background appears in the status bar when V*Home is delivering Ventilation therapy		The Ventilation icon with a white background appears in the status bar when the Leak+ feature is available, enabling High Flow therapy and Leak Compensation for patient circuit leaks up to 175 L/min at 20 cmH2O.
	This icon appears in the status bar when V*Home is delivering Oxygen therapy		This icon appears in the status bar when V*Home is delivering Nebulizer therapy
	This icon appears when a breath is patient-triggered		

Glossary of Terms

Term	Definition
AC	Alternating Current. V*Home can be connected to external, continuous sources of AC power, such as a wall outlet.
Apnea	The temporary cessation of a patient's ability to initiate breaths on their own.
Assist breath	A breath that is initiated by patient effort and cycled by V*Home.
BPM	Breaths Per Minute.
BTPS	Body Temperature and Pressure Saturated.
DC	Direct Current. V*Home can be connected to external sources of DC power, such as wheelchair outlets.

EPAP	Expiratory Positive Airway Pressure.
I:E Ratio	The ratio of inspiratory time to expiratory time.
IPAP	Inspiratory Positive Airway Pressure.
L/min	Liters per minute.
Mandatory breath	A breath that is initiated and cycled by V*Home.
MAP	Mean Airway Pressure. The MAP is the average patient airway pressure as measured over one full breath cycle.
PEEP	Positive End Expiratory Pressure.
PIP	Peak Inspiratory Pressure.
Sigh	The Sigh control can be set to deliver a breath at 150% the normal breath volume every 100th mandatory or assist breath.
SIMV	Synchronous Intermittent Mandatory Ventilation. Depending on the frequency of patient effort, mandatory, assist, and spontaneous breaths will be delivered to the patient as either volume or pressure breaths (depending on the ventilation mode selected).
Spontaneous breath	A breath that is initiated and cycled by patient effort.
Tidal Volume	The total volume of gas entering the lungs during one breath.
Vte	Exhaled Tidal Volume. The total volume of gas leaving the lungs during one breath.
ATPD	Ambient Temperature and Pressure, Dry.
PSIG	Pounds per square inch, gauge.

Troubleshooting

Some issues with V*Home can be resolved quickly by following the steps described in this chapter. Others may require service from an authorized Ventec Life Systems service technician. In case of V*Home malfunction, the clinician or caregiver must be able to provide an alternative means of ventilation promptly when necessary.

Troubleshooting Alarms

The V*Home operator must be capable of responding to alarm conditions and promptly performing the necessary corrective actions. See *“Alarms” on page 104* for information on each alarm condition, including the recommended actions associated with each.

Alarm	Recommended Troubleshooting Actions
<p>Apnea activates when V*Home has not delivered assist or spontaneous breaths (or coughs) for the set Apnea alarm duration.</p>	<ul style="list-style-type: none"> • Ensure the Apnea alarm is set appropriately given the patient’s Breath Rate and spontaneous rate. • Ensure the Flow Trigger control is set appropriately. • Check patient triggered icon and waveforms to determine if patient is attempting to initiate breaths. (If the patient is not initiating breaths, the alarm is working as intended.) • Check for problems with patient triggering such as low drive due to medication, or copious secretions, or excessive mask or cuff leak. • For Active circuits, turn on Leak Compensation if needed. • If the problem persists, replace the circuit.

Alarm	Recommended Troubleshooting Actions
<p>Battery Use activates whenever V*Home switches from external power to battery power, or from any power source (including removable battery) to internal battery power.</p> <p>Internal Battery Low activates when V*Home internal battery charge status falls below 50%.</p> <p>Internal Battery Critically Low activates when the internal battery is disconnected, faulty, or when the battery is critically low (charged to less than 33% its capacity).</p>	<p>When using battery power, battery alarms are normal.</p> <ul style="list-style-type: none"> • Monitor battery charge status, and connect an external source of power when available. • To clear the Battery Use alarm while using removable, rechargeable battery power, navigate to the Alarm Log and select “Clear List” twice. <p>When using AC power, check to ensure there’s a power connection symbol in the status bar. If the power symbol is present, V*Home is powered.</p> <ul style="list-style-type: none"> • Clear the alarm by navigating to the Alarm Log and selecting “Clear List” twice. <p>If there is no power connection symbol in the status bar:</p> <ul style="list-style-type: none"> • If the green light on the power adapter block is illuminated, check that all power adapter cabling is securely connected, and that the cable is securely connected to the power port in the back of V*Home. • If the green light on the power adapter block is off (not illuminated): <ul style="list-style-type: none"> • Ensure power adapter is plugged into the wall outlet. • Ensure the AC power cord is securely plugged into the power adapter block. • Plug something else into the same wall outlet to ensure it is powered. • If the problem persists, replace the AC power adapter.
<p>Check O2 Source activates when a connected source of external low-pressure oxygen is used and the monitored FiO2 falls below 24%.</p>	<ul style="list-style-type: none"> • Check to ensure the low-pressure oxygen source is connected. • Make sure the low-pressure oxygen source is turned on and is producing oxygen, or is not depleted.
<p>Check Patient Circuit activates when V*Home detects an inadequate leak in a passive or valveless circuit.</p>	<ul style="list-style-type: none"> • Run a Pre-Use Test. This step insures the selected circuit is correct. • For Passive circuits, check the V*Home Leak monitor. If needed, locate and resolve any unintentional leaks in the patient circuit (or around the patient interface), and ensure the exhalation valve is not obstructed (for example, by crystallized medications in the exhalation valve). • If using a nebulizer (particularly with sticky medications), install a filter (HMEF or bacterial filter) between the nebulizer and the patient circuit exhalation valve. • For heated circuits, ensure there is no water accumulation in the tubing or valve. • If the problem persists, replace the patient circuit.

Alarm	Recommended Troubleshooting Actions
<p>Device Expired - Maximum Hours activates when the 5 yrs. PM Due In monitor is at or below 0, indicating that V*Home has reached the end of its useful life. This alarm can be reset for up to 8 hours by clearing the alarm.</p>	<ul style="list-style-type: none"> • Dispose of the V*Home in accordance with local regulations.
<p>High Breath Rate activates when the monitored breath rate is higher than the set High Breath Rate alarm limit.</p>	<ul style="list-style-type: none"> • Ensure the High Breath Rate alarm is set above the patient Breath Rate plus spontaneous rate. • Check for patient secretions, and use Suction therapy to clear them if needed. • Empty any excess condensation in the patient circuit. • Check the V*Home Leak monitor. If it is high, locate and resolve any unintentional leaks in the patient circuit (and around the patient interface). • If V*Home is auto-triggering, adjust the Flow Trigger setting if needed.
<p>High FiO2 activates when the monitored FiO2 percentage is higher than the set High FiO2 alarm limit.</p>	<ul style="list-style-type: none"> • When using high flow therapy, check to ensure there are no unintended sources of gas or oxygen connected to V*Home or the patient circuit.
<p>High Minute Volume activates when the monitored Minute Volume is larger than the set High Minute Volume alarm limit.</p>	<ul style="list-style-type: none"> • Ensure the alarm is set appropriately for the patient Breath Rate plus spontaneous rate. • Check to see if the monitored Breath Rate is high. If so: <ul style="list-style-type: none"> • Check for auto-triggering and adjust the Flow Trigger control setting if needed.
<p>High PEEP (or High EPAP in Bi-Level Mode) activates when the monitored PEEP is greater than PEEP plus the set High PEEP alarm limit.</p>	<ul style="list-style-type: none"> • Note that if the alarm occurs while the patient is breath stacking, it is working as intended. • Check for auto-triggering and adjust the Flow Trigger control setting if needed. • If the problem persists, replace the patient circuit.
<p>High Pressure activates when the monitored Airway Pressure exceeds the set High Pressure alarm limit for more than the number of consecutive breaths set with the High Pressure Delay control.</p>	<ul style="list-style-type: none"> • Ensure the High Pressure alarm is set appropriately for the patient as their condition changes (for example, through sneezes, coughs, and/or yawns). • Check for blockages or obstructions in the circuit and patient airway. (For example, saturated or clogged HME or bacterial filters, in-line suction catheters, or patient secretions during volume ventilation.) • If the problem persists, replace the patient circuit.

Alarm	Recommended Troubleshooting Actions
<p>Inop activates when V*Home experiences a loss of power without available battery backup power, when the battery depletes and is the only available source of power, or when a software or hardware failure renders V*Home unable to safely deliver therapy and/or monitor the patient.</p>	<ul style="list-style-type: none"> • Immediately provide the patient with an alternate source of ventilation. • Press the On/Off button again to restart V*Home. • If the device remains inoperative, contact your local Ventec Life Systems representative for service.
<p>Low Breath Rate activates when the monitored Breath Rate is less than the set Low Breath Rate alarm limit.</p>	<ul style="list-style-type: none"> • Ensure the alarm limit is set appropriately for the patient Breath rate plus spontaneous rate. • Check patient and waveforms to determine if patient is attempting to initiate breaths. (If the patient is not initiating breaths, the alarm is working as intended.) • Check to ensure all connected components are clean and not clogged (such as filters and HMEs). • Ensure the Flow Trigger control is set appropriately. • If the problem persists, replace the patient circuit.
<p>Low FiO₂ activates when the monitored FiO₂ falls below the set Low FiO₂ alarm limit.</p>	<ul style="list-style-type: none"> • When using high flow therapy, ensure the Low FiO₂ alarm setting is appropriate for the delivered FiO₂. • Verify the O₂ Low-Pressure Inlet adapter is installed.
<p>Low Inspiratory Pressure activates when the monitored Peak Inspiratory Pressure falls below the set Low Inspiratory Pressure alarm limit.</p>	<ul style="list-style-type: none"> • Ensure the Low Inspiratory Pressure alarm is set below the patient peak inspiratory pressure, taking into account changes in airway resistance and/or lung recruitment. • Check the V*Home Leak monitor. If it is high, locate and resolve any unintentional leaks in the patient circuit (and around the patient interface). • If the problem persists, replace the patient circuit.
<p>Low Minute Volume activates when the monitored Minute Volume falls below the set Low Minute Volume alarm limit.</p>	<ul style="list-style-type: none"> • Ensure the Low Minute Volume alarm is set appropriately, taking into account changes in patient breathing habits at night. • Check the V*Home Leak monitor. If it is high, locate and resolve any unintentional leaks in the patient circuit (and around the patient interface). If using a trach tube, ensure the cuff is properly inflated. • During pressure-control ventilation, check the patient for reduced lung compliance or airway blockages.

Alarm	Recommended Troubleshooting Actions
<p>Low PEEP (or Low EPAP in Bi-Level Mode) activates when the monitored PEEP falls 5 cmH₂O below the set PEEP control for 3 consecutive breaths.</p>	<ul style="list-style-type: none"> • Check the V*Home Leak monitor. If it is high, locate and resolve any unintentional leaks in the patient circuit (and around the patient interface). • Run a Pre-Use Test. • If the alarm continues, replace the patient circuit.
<p>Maintenance Due activates when the Sys. PM Due In monitor falls below 0, indicating that V*Home is due for maintenance. This alarm can be reset for up to 32 hours by clearing the alarm.</p>	<ul style="list-style-type: none"> • When convenient, contact your local Ventec Life Systems representative to schedule service. (Note that this alarm will activate every 32 hours until service is completed.)
<p>Patient Circuit Disconnect activates when V*Home detects a large leak in a passive or valveless Ventec One-Circuit. (See below for alarm behavior during High Flow therapy.)</p>	<ul style="list-style-type: none"> • Check the V*Home Leak monitor. If it is high, locate and resolve any unintentional leaks in the patient circuit (and around the patient interface). • Run a Pre-Use Test and ensure the Circuit Type control matches the type of circuit connected to V*Home. • If the problem persists, replace the patient circuit.
<p>Patient Circuit Disconnect (during High Flow therapy) activates when no patient breathing is detected for 20 seconds.</p>	<ul style="list-style-type: none"> • Ensure the high flow nasal cannula (or other interface) is properly fitted to the patient. • If the problem persists, replace the high flow nasal cannula.
<p>System Fault activates if V*Home detects any one of multiple system fault conditions.</p>	<ul style="list-style-type: none"> • Use the Event Log to determine the System Fault number, then see <i>"System Fault Detection Criteria and Recommended Action"</i> on page 177 and then take the corresponding action.
<p>Very Low FiO₂ activates when the monitored FiO₂ is less than 18%.</p>	<ul style="list-style-type: none"> • Ensure there the V*Home air inlets are not blocked, and that there is adequate air flow around the device. • Remove any oxygen sources connected to V*Home or the patient circuit. <ul style="list-style-type: none"> • If the Very Low FiO₂ alarm resolves, troubleshoot problems with the oxygen source. • If the Very Low FiO₂ persists there may be a problem with the V*Home oxygen sensor. Contact your local Ventec Life Systems representative for service.

Device Troubleshooting

Problem	Cause	Solution
V*Home enclosure is abnormally warm	Air and/or fan filter is clogged	Clean and replace the air and fan filter. If the filters appear damaged, replace them
V*Home will not power on	The internal and removable batteries are fully discharged	Plug V*Home into a wall outlet. Ensure the wall outlet is functional and not controlled by a switch
	V*Home requires service	Contact Ventec Life Systems for service
V*Home will not power off	Touchscreen is not responsive	Press and hold the power button for more than 10 seconds
Batteries are not charging	V*Home is operating at a temperature outside its environmental specifications, or the batteries are overheated	Verify that V*Home is not close to a heat source. Move V*Home to a cooler location if required
	Fan filter is clogged, causing VOCSN to overheat	Clean the fan filter
Device performance changes	Electrical interference	Move V*Home away from any potential sources of electromagnetic interference (EMI) including MRI equipment, medical imaging systems, security systems, appliances, wireless communications equipment (such as cellular phones), computers, and televisions
	V*Home requires a restart	Press the On/Off button and power off V*Home. Press the On/Off button again to restart V*Home
	V*Home requires service	Contact Ventec Life Systems for service

Ventilation and Troubleshooting

Problem	Cause	Solution
Abnormally warm gas is flowing through the Ventec One-Circuit	Air filter is clogged	Clean and replace the air filter. If the air filter appears damaged, replace it with a new one
	V*Home is not properly ventilated	Move V*Home away from cluttered areas, bedding, curtains, or anything else that could impede air flow around the device
	V*Home is too close to a heat source	Move V*Home out of direct sunlight and away from any other sources of heat
	V*Home requires service	Contact Ventec Life Systems for service.
Patient tubing and flow sensor lines contain condensation	Use of a humidifier requires water management	Use a Ventec One-Circuit with heated wire
Vte and Minute Volume monitors are high	Condensation in the active Ventec One-Circuit exhalation valve	Remove the condensation from the exhalation valve Adjust the humidification to prevent condensation from building up in the exhalation valve Replace the patient circuit.
Vte monitor is high	A test lung, ET tube, trach tube, or HME is connected directly to an active exhalation valve.	Connect a flex tube to the active exhalation valve.
High or Low Vte monitors, autocycling, and/or low delivered pressure.	Active Ventec One-Circuit multilumen tube is not fully connected to the V*Home "Active" port.	Tighten the active valve multilumen tube connection. Check all three rubber tube connections on the active exhalation valve. Replace the patient circuit.
System Fault 3, high or low Vte monitors, and autocycling	Water from a humidifier is in the Ventec One-Circuit multilumen sense lines.	Replace the patient circuit.
V*Home prompts user to run Pre-Use Test when switching between two Mouthpiece ventilation Presets	The Humidification control is not user editable, but is set to HME for one Preset, and Humidifier for the other preset	Change the Circuit Type control from Mouthpiece to Passive. If necessary, change the Humidification control from Humidifier to HME. Change the Circuit Type control back to Mouthpiece. Repeat the steps above for all Ventilation therapy Presets used to provide mouthpiece ventilation

Oxygen Troubleshooting

Problem	Cause	Solution
Patient desaturation	O2 monitoring equipment is not connected.	Ensure the O2 monitoring equipment is connected to the patient.

Multi-View Troubleshooting

Problem	Cause	Solution
Export stalls while writing to USB drive	USB drive is corrupt	Use a new USB 2.0 drive formatted to FAT32.

Patient Circuit Troubleshooting

Problem	Cause	Solution
Patient circuit performance	Obstructions in the patient circuit	Ensure connected patient circuit accessories (such as an HME or humidifier) are clean and not obstructed.
	Circuit Type control is not set correctly	Ensure that the Circuit Type control settings matches the circuit type connected to V*Home, and run a Pre-Use Test.

Recalibrating Batteries

Over time, the V*Home batteries (the removable, rechargeable batteries and/or the internal battery) may require recalibration to report their charge status correctly in the V*Home status bar.

If the three relative state of charge icons in the V*Home status bar do not report that the batteries are fully charged even after V*Home has been plugged in for 24 hours or more, disconnect V*Home from the patient and recalibrate the batteries by following these steps:

- 1** Plug V*Home into external power and charge the batteries until the charge status LED on the front of the device turns green.
- 2** Unplug V*Home from external power to begin draining the batteries.
- 3** Discharge all three batteries completely. V*Home will alarm and shut down when no battery power remains.
- 4** Allow V*Home to sit off and disconnected from external power for at least 5 hours.
- 5** Plug V*Home into external power and charge the batteries uninterrupted until the charge status LED on the front of the device turns green for at least 30 minutes.

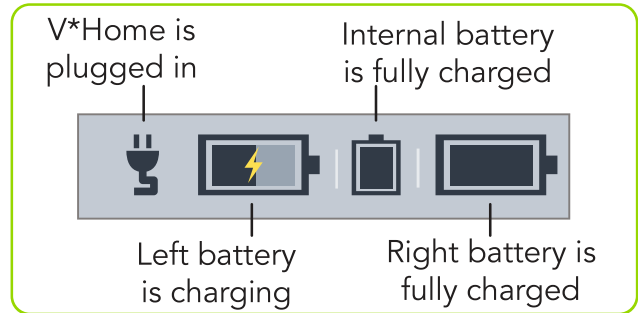

- Batteries are charging (orange)
- All batteries are fully charged (green)

NOTE: In addition to the relative state of charge status shown in the status bar, V*Home reports the battery absolute state of charge. These values naturally decrease over time and are shown on the My VOCSN screen. When the absolute state of charge of a battery is <50% after charging for 24 hours, the battery should be replaced.

Technical Specifications

This chapter provides V*Home technical specifications, including environmental requirements and the accuracy specifications of all controls and monitors.

NOTE: V*Home will continue to meet its stated performance specifications when operating on battery power.

Physical

Physical Category	Specification
V*Home	Dimensions: 10.25" wide, 11" high, 7.5" deep (26 cm wide, 27.9 cm high, 19.1 cm deep) Weight (with removable, rechargeable batteries installed) per configuration: <ul style="list-style-type: none"> V*Home: 12 lbs (5.4 kg)
Rechargeable, removable batteries	Dimensions: 2.7" wide, 3.9" high, 2.2" deep (6.9 cm wide, 9.9 cm high, 5.5 cm deep) Weight: 1 lb 1 oz (484 g)

Environmental

NOTE: Unless otherwise specified, the following environmental specifications apply to all V*Home components, controls, alarms, and monitors.

Environmental Category	Specification
Temperature and Relative Humidity	Operating: +5 °C to +40 °C; 15% to 90% relative humidity, non-condensing Storage and transport: -25 °C at any humidity to +70 °C at up to 90% relative humidity, non-condensing
Atmospheric Pressure	Operating: 700 to 1060 hPa Storage: 500 to 1100 hPa
Drop	Without protective case: 0.1 meters per IEC 60068-2-3
Ingress	IP32 per IEC 60529. Protected against dripping water and ingress of tools and thick wires
Shock	Storage: 15g per IEC 60068-2-27 Operating: 5g per IEC 60068-2-27
Vibration	Storage: 1.0 (m/s ²)/Hz per IEC 60068-2-64 Operating: 0.33 (m/s ²)/Hz per IEC 60068-2-64

Inputs and Outputs

Category	Specification
Low-pressure O2 inlet	CPC MC1602 Flow ≤20 L/min
USB	USB 2.0, FAT32 Format
Ventec One-Circuit connection port	22mm male conical fitting per ISO 5356-1

External Power Requirements

Category	Specification
----------	---------------

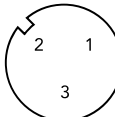
AC power	<p>Sine AC mains waveform Rated Voltage: 100 to 240 VAC, 50 to 60 Hz Power for V+O+C+S+N(+Pro) configurations: ≤288 VA average, 420 VA peak Power for V+C(+Pro) configurations: ≤180 VA average, 240 VA peak</p>
DC power	<p>20.0 to 30.3 VDC, as measured at the connection to the device, through 0 to 350 W instantaneous loads</p> <p>Power for V+O+C+S+N(+Pro) configurations: ≤200 W average, 350 W peak Power for V+C(+Pro) configurations: ≤150 W average, 200 W peak</p> <p>Intended for connection to 24 V (27.2 VDC typical) batteries</p> <p>Female XLR3 connection port with the following pin configuration:</p>  <p>Pin 1 Signal: V+ Pin 2 Signal: RTN Pin 3 Signal: N/A (Unused by V*Home)</p>

Removable, Rechargeable Batteries

Category	Specification
Operating time	With ventilation at nominal settings and new batteries, approximate run time is 6 hours on set of removable batteries.
Capacity	5.8 Ahr
Voltage	14.4 VDC
Charging	Each removable battery requires 5 hours, typical, from full discharge to full charge. If fully discharged, charging time for the 2 removable batteries and Internal battery may require up to 14 hours.

Internal Rechargeable Battery

Category	Specification
Operating time	With ventilation at nominal settings and a new battery, approximate run time is 2 hours.
Capacity	3.9 Ahr
Voltage	14.4 VDC
Charging	<p>If fully discharged, charging time for the 2 removable batteries and Internal battery may require up to 14 hours.</p> <div style="border: 1px solid black; border-radius: 10px; padding: 5px; margin-top: 10px;"> <p>NOTE: The power supply provided with V*Home is >14 V. Charging time increases if a <14 V external power source is applied.</p> </div>

Expected Service Life and Intervals

Category	Expected service life
V*Home	2 years or 10,000 hours of use (whichever is less)
Removable, rechargeable batteries	2 years or 500 complete charge/discharge cycles (whichever is less)

Audible Volume

Category	Volume
Ventilator	≤ 48 dBA at 1 meter
Inop alarm	65 to 90 dBA at 1 meter
Alarm at High volume	85 +15/-5 dBA at 1 meter
Alarm at Medium volume	75 +15/-5 dBA at 1 meter
Alarm at Low volume	65 +15/-5 dBA at 1 meter

FiO2 Monitor

Category	Specification
Time to Essential Performance	5 min
Sample Rate	360 ms (2.78 Hz)
Response Time	≤ 30 s to 90% of actual
Accuracy	See <i>"Monitor Resolution and Accuracy"</i> on page 158.
Range	15 to 95%, >95%
Drift	0.4% of reading per 10,000 hours of use

Control Accuracy

NOTE: Negative (subatmospheric) pressure is not available during the expiratory phase of ventilation therapy breaths delivered by V*Home.

NOTE: When used with active, passive, or valveless Ventec One-Circuits, V*Home was designed for use with a humidifier or HME. All volumes and flows are expressed in BTPS unless stated otherwise.

Control	Accuracy
Apnea Rate	± 1 BPM or $\pm 10\%$ of setting, whichever is greater
Breath Rate	Accuracy: ± 1 breath/minute, or $\pm 10\%$ of setting, whichever is greater Stability: $\pm 10\%$ of setting
EPAP	See PEEP.
Flow	$\pm(10\%$ of setting or 1 L/min, whichever is greater)
Flow Cycle	$\pm 10\%$ for active and mouthpiece circuits $\pm 15\%$ for passive and valveless circuits
Flow Trigger	± 1 L/min when PEEP is set to 0 cmH ₂ O ± 1.5 L/min when PEEP is set to 1 to 6 cmH ₂ O ± 2 L/min when PEEP is set to 7 to 16 cmH ₂ O ± 2.2 L/min when PEEP is set from 17 to 25 cmH ₂ O
Humidification	N/A
Inspiratory Time	Accuracy: $\pm(10\%$ of setting + 0.1 seconds) Stability: $\pm(10\%$ of setting + 0.1 seconds)
IPAP	$\pm(8\%$ of setting or 2 cmH ₂ O, whichever is greater)
Leak Compensation	N/A
Nebulizer Duration	± 1 minute
Patient Type	N/A
Pause Time	$\pm(10\%$ of setting + 0.1 seconds)
PC Flow Termination	N/A
PEEP/EPAP	$\pm(10\%$ of setting + 1 cmH ₂ O)
Pressure Control	$\pm(8\%$ of setting or 2 cmH ₂ O, whichever is greater)
Pressure Support	$\pm(8\%$ of setting or 2 cmH ₂ O, whichever is greater)
Rise Time	N/A
Sigh	N/A

Control	Accuracy
Tidal Volume	Measured at the patient connection port Accuracy: $\pm(10\%$ of setting + 5 mL) for active and mouthpiece circuits; $\pm(15\%$ of setting + 7.5 mL) for passive and valveless circuits Stability: $\pm(10\%$ of setting + 5 mL)
Time Cycle	$\pm(10\%$ of setting + 0.1 seconds)

Monitor Resolution and Accuracy

NOTE: When used with passive, or valveless Ventec One-Circuits, V*Home was designed for use with a humidifier or HME. All volumes and flows are expressed in BTPS unless stated otherwise.

NOTE: Monitors incorporating pressure measurements are calculated using a pressure sensor inside V*Home, which calculates the pressure at the Ventec One-Circuit connection port.

NOTE: Unless otherwise stated, monitor accuracy specifications are met when V*Home is used as recommended by Ventec Life Systems.

Monitor	Resolution	Accuracy
Airway pressure manometer	N/A	±(1.4 cmH ₂ O + 8% of actual) up to 15 cmH ₂ O ±(2 cmH ₂ O + 4% of actual) above 15 cmH ₂ O
Breath Rate	1 BPM	±10% BPM
Date	1 day	N/A
FiO ₂	1%	±(2.5% + 2.5% of actual) NOTE: Air contaminants and pollutants (including methane) may have an adverse effect on the accuracy and long-term performance of the FiO ₂ monitor.
I:E Ratio	0.1	Calculated from the average monitored inspiratory time and average monitored exhalation time accuracies of ±50 ms or 5%, whichever is greater
Internal Battery Capacity	N/A	N/A
Leak	1 L/min	±(10% + 1 L/min)
MAP	1 cmH ₂ O	See Airway pressure manometer
Minute Volume	0.1 L when ≤9.9 1.0 L when ≥10	Calculated (for active circuits) or estimated (for passive and valveless circuits) from the average exhaled tidal volume (V _{te}) and number of breaths per minute (BPM) for the last 8 breaths
Nebulizer Minutes Remaining	1 minute	±1 minute
Patient Triggered	N/A	N/A
PEEP	1 cmH ₂ O	±(1.4 cmH ₂ O + 8% of actual) up to 15 cmH ₂ O ±(2 cmH ₂ O + 4% of actual) above 15 cmH ₂ O
PIP (Peak Inspiratory Pressure)	1 cmH ₂ O	±(1.4 cmH ₂ O + 8% of actual) up to 15 cmH ₂ O ±(2 cmH ₂ O + 4% of actual) above 15 cmH ₂ O

Monitor	Resolution	Accuracy
Removable Battery 1 Capacity	N/A	N/A
Removable Battery 2 Capacity	N/A	N/A
System Usage	1 hour	N/A
Sys. PM Due In Time	1 hour	N/A
Vte / Est. Vte	1 mL	$\pm(4.0 \text{ mL [Vtes >50 mL]} \text{ or } 15 \text{ mL [Vtes} \leq 50 \text{ mL]} + 15\% \text{ of actual})$

Classifications

Category	Classification
Electrical Safety	Class II Continuous Portable Internally Powered Transit Operable Type BF Applied Parts
Applied Parts	Ventec One-Circuit

Standards Applied

Category	Standard
Critical care ventilators	ISO 80601-2-12
Home care ventilators	ASTM F1246
Breathing sets and connectors	ISO 5367
Respiratory gas monitors	ISO 80601-2-55
Medical electrical equipment	IEC 60601-1
Alarm system	IEC 60601-1-8
Medical devices for home use	IEC 60601-1-11
Nebulizing system	ISO 27427

Ventec One-Circuit Compliance

NOTE: Based on the set Patient Type and Humidification Type, V*Home automatically adjusts delivered therapy to compensate for differences in the compliance and volume of the Ventec One-Circuit.

NOTE: The maximum working pressure of Ventec One-Circuits is 70 cmH₂O.

Ventec One-Circuit	Compliance
Adult Ventec One-Circuits	With connected humidifier: 1.4 mL/cmH ₂ O With connected HME: 1.1 mL/cmH ₂ O
Pediatric Ventec One-Circuits	With connected humidifier: 1.0 mL/cmH ₂ O With connected HME: 0.7 mL/cmH ₂ O

Pressure During Inop

VOCSN System	Pressure ¹
Adult	1.66 cmH ₂ O during exhalation at 30 L/min 3.67 cmH ₂ O during inspiration at 30 L/min
Pediatric	0.69 cmH ₂ O during exhalation at 15 L/min 1.38 cmH ₂ O during inspiration at 30 L/min

Biocompatibility

Category	Compliance
Biocompatibility	Meets the requirements of ISO 10993-1 for Tissue/Bone/Dentin Externally Communicating Devices with a permanent contact duration
Volatile Organic Compounds (VOCs) delivered to the patient	<10% of the American Conference of Industrial Hygienists (ACGIH) Threshold Limit Values
Particulate matter delivered to the patient	<12 µg/m ³ per the EPA Fine Particle PM _{2.5} requirements
Allergens	This product is not made with natural rubber latex. No parts of this product that directly or indirectly contact the patient are made with the plasticizer Diethylhexyl phthalate (DEHP).

Accessories

Available from Ventec Life Systems

The following parts and accessories are available for use with V*Home. Contact your local Ventec Life Systems representative for more information about available components and accessories, or to place an order:



Photo	Item name	Description
	<p>24 Volt Wheelchair Power Cable</p>	<p>The 24 Volt Wheelchair Power Cable can be used to connect V*Home to wheelchair power outlets.</p>
	<p>AC Power Adapter</p>	<p>10-foot, two-prong AC power cable and 3-foot AC/DC power adapter. The power connector includes a threaded locking mechanism to reduce the risk of accidental disconnects. Wire retention clip ensures the power supply cord remains firmly connected to the adapter. LED on the power adapter indicates proper power connection. The power supply also comes with a hook-and-loop strap to manage excess cabling. This power adapter recharges the three lithium-ion batteries while V*Home is on or off.</p>
	<p>Carry Bag</p>	<p>The VOCSN Carry Bag supports everyday mobility with an included shoulder strap and multiple attachment points to secure V*Home to a wheelchair, bed rail, or other mount. The Carry Bag is designed to accommodate full V*Home functionality while attached. It is compatible with the Roll Stand, Travel Suction Canister, and allows access to both removable, rechargeable batteries.</p>





Photo	Item name	Description
	<p>External Bacterial Filter</p>	<p>The Ventec Bacterial Filter helps to protect both the patient and V*Home from contamination from airborne microorganisms. The bacterial and viral filtration efficiency (BFE and VFE) is >99.99%.</p>
	<p>Fan Filter</p>	<p>The washable and reusable foam fan filter cleans air entering the cooling fan intake.</p>
	<p>Internal Bacterial Filter</p>	<p>The secondary, low resistance, internal bacterial filter eliminates 99.99% of bacteria and viruses to protect against cross-contamination. Serviceable by trained technicians, typically during 10,000-hour scheduled maintenance. Refer to page 166 for Internal Bacterial Filter replacement instructions.</p>
	<p>Nurse Call Cable (Normally Closed - White)</p>	<p>Connects VOCSN to normally closed remote alarm, nurse call, or other alarm systems that sense contact closure through a 1/4 in. (.6 cm) phono jack.</p>
	<p>Nurse Call Cable (Normally Open - Black)</p>	<p>Connects VOCSN to normally open remote alarm, nurse call, or other alarm systems that sense contact closure through a 1/4 in. (.6 cm) phono jack.</p>



Photo	Item name	Description
	<p>O2 Low-Pressure Inlet Adapter</p>	<p>The O2 Low-Pressure Inlet Adapter inserts into the low-pressure oxygen port on the back of VOCSN to connect to a low-pressure oxygen source.</p>
	<p>Patient Air Intake Filter</p>	<p>This washable and reusable foam filter cleans air entering the patient air intake.</p>
	<p>Removable, Rechargeable Batteries, Lithium-Ion</p>	<p>Set of two lithium-ion 14.4V 5.8Ahr hot-swappable batteries with integrated push button charge indicator. Batteries can be charged in VOCSN or with the detachable battery quick charger. (Battery Quick Charger sold separately.)</p>
	<p>Removable Battery Quick Charger</p>	<p>60W desktop charger for two VOCSN detachable batteries. Indicator lights display battery charge status. Each battery charges fully in three hours. The charger is powered by a standard two-prong AC cord. (Batteries not included)</p>

Photo	Item name	Description
	<p>Roll Stand</p>	<p>The Ventec Roll Stand is a mobile, wheeled mount for VOCSN, and includes a mounting bracket, utility bracket, straps, and a cable hook for cord management.</p>
	<p>Ventec One-Circuit, Passive: adult or pediatric, single-patient use</p>	<p>Passive Ventec One-Circuits are single-limb circuits with a fixed-leak passive exhalation port.</p> <p>Adult and pediatric passive Ventec One-Circuits can be purchased with or without the following optional features:</p> <ul style="list-style-type: none"> • Heated wire, used to manage the accumulation of water in the Ventec One-Circuit when connected to a humidifier. • Ventec One-Circuit O2 tube, used to deliver pulse dose Oxygen Direct therapy.
	<p>Ventec One-Circuit, Valveless: adult or pediatric, single-patient use</p>	<p>Adult and pediatric Valveless Ventec One-Circuits are single-limb circuits without an exhalation valve for use with vented masks.</p> <p>Adult and pediatric valveless Ventec One-Circuits can be purchased with or without the following optional features:</p> <ul style="list-style-type: none"> • Heated wire, used to manage the accumulation of water in the Ventec One-Circuit when connected to a humidifier.

Available from Other Manufacturers

The following third-party components or accessories are approved for use with VOCSN. To ensure proper device performance and patient safety, third-party parts used with VOCSN should meet the requirements listed in the table below

Third-party component or accessory	Requirement for safe use with VOCSN
Heat-Moisture Exchanger (HME)	Compliant with ISO 9360-1 or ISO 9360-2.
Humidifier	Compliant with ISO 8185. Ventec Life Systems recommends use of the Fisher & Paykel HC550, the Fisher & Paykel MR850, or equivalent.
Mouthpiece Circuit Kit, single-patient use	The Mouthpiece Circuit Kit is a third-party accessory available through Ventec Life Systems. It includes a 15 mm patient circuit, a mouthpiece, flexible extension, connection adapters, and a support arm.
Data Streaming Device	Ventec Life Systems recommends use of React DataLink by Bridge-Tech Medical.
Nebulizer	Compliant with the relevant requirements of ISO 27427

EMC Information

The EMC information provided in this chapter applies to V*Home and its accessories, including the AC Adapter, 24 Volt Wheelchair Power Cable, and Nurse Call Cable.

WARNING: To protect against EMI (electromagnetic interference) affecting device performance:

- Do not use V*Home within electromagnetic fields exceeding the limits specified in this chapter. Common sources of electromagnetic fields include security systems, wireless communications equipment, appliances, and medical imaging systems.
- Do not stack V*Home with other electrical devices during use.
- Do not connect V*Home to unauthorized cables or accessories. Use of cables or other accessories not approved for use with V*Home may result in increased electromagnetic emissions or decrease its immunity from other sources of EMI.

Electromagnetic Emissions

V*Home is intended for use in the electromagnetic environment specified below. The user of this device should make sure it is used in such an environment.

Emissions Test	Compliance	Guidance: Electromagnetic Environment
RF emissions CISPR 11	Group 1	V*Home uses RF energy only for its internal function. Therefore, its RF emissions are very low and are not likely to cause any interference in nearby electronic equipment.
RF emissions	Class B	V*Home is suitable for use in all establishments, including domestic establishments and those directly connected to the public low-voltage power supply network that supplies buildings used for domestic purpose.
Harmonic emissions IEC 61000-3-2	Class A	
Voltage fluctuations/Flicker emissions IEC 61000-3-3	Complies	

Electromagnetic Immunity

V*Home is intended for use in the electromagnetic environment specified below. The user of this device should make sure it is used in such an environment.

Immunity Test	IEC 60601 Test Level	Compliance Level	Guidance: Electromagnetic Environment
Electrostatic Discharge (ESD) IEC 61000-4-2	±6 kV contact ±8 kV air	±8 kV contact ± 15 kV air	Floors should be wood, concrete, or ceramic tile. If floors are covered with synthetic material, the relative humidity should be at least 30%.
Electrical fast Transient/burst IEC 61000-4-4	±2 kV for power supply lines ±1 kV for input/output lines	±2 kV for supply mains ±1 kV for input/output lines	Mains power quality should be that of a typical home or hospital environment.
Surge IEC 61000-4-5	±1 kV differential mode ±2 kV common mode	±1 kV differential mode ±2 kV common mode	Mains power quality should be that of a typical home or hospital environment.
Voltage dips, short interruptions, and voltage variations on power supply input lines IEC 61000-4-11	<5% U_T (>95% dip in U_T) for 0.5 cycle 40% U_T (60% dip in U_T) for 5 cycles 70% U_T (30% dip in U_T) for 25 cycles <5% U_T (>95% dip in U_T) for 5 seconds NOTE: U_T is the AC mains voltage prior to application of the test level.	<5% U_T (>95% dip in U_T) for 0.5 cycle 40% U_T (60% dip in U_T) for 5 cycles 70% U_T (30% dip in U_T) for 25 cycles <5% U_T (>95% dip in U_T) for 5 seconds	Mains power quality should be that of a typical home or hospital environment. If the user of the device requires continued operation during power mains interruptions, it is recommended that the device be powered from an uninterruptible power supply or battery.
Power frequency (50/60 Hz) magnetic field IEC 61000-4-8	3 A/m	30 A/m	Power frequency magnetic fields should be at levels characteristic of a typical home or hospital environment.

Immunity Test	IEC 60601 Test Level	Compliance Level	Guidance: Electromagnetic Environment
			<p>Portable and mobile RF communications equipment should be used no closer to any part of the device, including cables, than the recommended separation distance calculated from the equation applicable to the frequency of the transmitter.</p> <p>Recommended separation distance:</p>
Conducted RF IEC 61000-4-6	3 Vrms 150 kHz to 80 MHz outside ISM bands ¹	3 V	$d = 1.2 \sqrt{P}$
	10 Vrms 150 kHz to 80 MHz in ISM bands ^a	10 V	$d = 1.2 \sqrt{P}$

Radiated RF
IEC 61000-4-3

10 V/m
80 MHz to 2.5 GHz

20 V/m
80 MHz to 2.5 GHz

$d = 0.6 \sqrt{P}$ 80 MHz to 800 MHz
 $d = 1.2 \sqrt{P}$ 800 MHz to 2.5 GHz

where P is the maximum output power rating of the transmitter in watts (W) according to the transmitter manufacturer and d is the recommended separation distance in meters (m).

Field strengths from fixed RF transmitters, as determined by an electromagnetic site survey^a, should be less than the compliance level in each frequency range.²

Interference may occur in the vicinity of equipment marked with the following symbol:



NOTE 1: At 80 MHz and 800 MHz, the higher frequency range applies.

NOTE 2: These guidelines may not apply in all situations. Electromagnetic propagation is affected by absorption and reflection from structures, objects, and people.

1 Field strengths from fixed transmitters, such as base stations for radio (cellular/cordless) telephones and land mobile radios, amateur radio, AM and FM radio broadcast and TV broadcast cannot be predicted theoretically with accuracy. To assess the electromagnetic environment due to fixed RF transmitters, an electromagnetic site survey should be considered. If the measured field strength in the location in which the device is used exceeds the applicable RF compliance level above, the device should be observed to verify normal operation. If abnormal performance is observed, additional measures may be necessary, such as re-orienting or relocating the device.

2 Over the frequency range 150 kHz to 80 MHz, the field strengths should be less than 3 V/m.

Recommended Separation Distance Between Portable and Mobile RF Communications Equipment and V*Home

V*Home is intended for use in an electromagnetic environment in which radiated RF disturbances are controlled. The customer or the user of this device can help prevent electromagnetic interference by maintaining a minimum distance between portable and mobile RF communications equipment (transmitters) and this device as recommended below, according to the maximum output power of the communications equipment.

Rated Maximum Power Output of Transmitter (Watts)	Separation Distance According to Frequency of Transmitter (meters)			
	150 kHz to 80 MHz outside ISM Bands $d = 1.2 \sqrt{P}$	150 kHz to 80 MHz in ISM Bands $d = 1.2 \sqrt{P}$	80 MHz to 800 MHz $d = 0.6 \sqrt{P}$	800 MHz to 2.5 GHz $d = 1.2 \sqrt{P}$
0.01	0.12	0.12	0.06	0.12
0.1	0.38	0.38	0.19	0.38
1	1.2	1.2	0.6	1.2
10	3.8	3.8	1.9	3.8
100	12	12	6	12

For transmitters rated at a maximum output power not listed above, the recommended separation distance d in meters (m) can be estimated using the equation applicable to the frequency of the transmitter, where P is the maximum output power of the transmitter manufacturer.

Note 1: At 80 MHz and 800 MHz, the higher frequency range applies.

Note 2: The ISM (industrial, scientific, and medical) bands between 150 kHz and 80 MHz are 6.765 MHz to 6.795 MHz; 13.553 MHz to 13.567 MHz; 26.957 MHz to 27.283 MHz; and 40.66 MHz to 40.70 MHz.

Note 3: An additional factor of 10/3 is used in calculating the recommended separation distance for transmitters in the ISM frequency bands between 150 kHz and 80 MHz and in the frequency range of 80 MHz and 2.5 GHz to decrease the likelihood that mobile/portable communications equipment could cause interference if it is inadvertently brought into patient areas.

Note 4: These guidelines may not apply in all situations. Electromagnetic propagation is affected by absorption and reflection from structures, objects, and people.

Technical Description

Theory of Operation

The sections that follow detail the theory of operation of each of the five V*Home therapies. A pneumatic schematic of each therapy is also provided.

Ventilation Therapy

Gas is drawn from the air intake, filtered for dust and particles, and flows into the accumulator. The air is mixed with oxygen if V*Home is configured to deliver a set FiO₂. The accumulator also serves as a muffler for the blower.

The gas passes through the internal flow transducer, which measures flow, and then moves through the blower and through the bacterial filter. Gas flows through the connected patient circuit to deliver the configured Ventilation therapy.

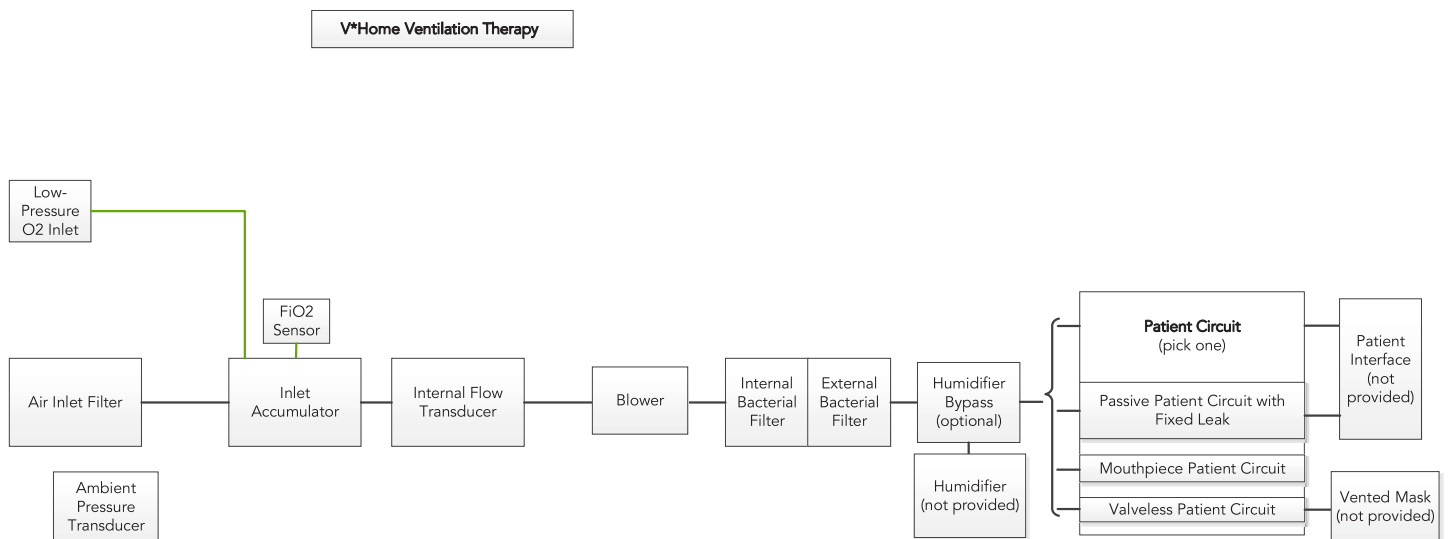

Leak Compensation

With Leak+ hardware configurations, the powerful V*Home leak compensation algorithm can compensate for leaks up to 175 L/min at 20 cmH₂O. Leak compensation works differently depending on the type of patient circuit and the ventilation mode used. The following table illustrates when V*Home leak compensation is active. The sections that follow include a detailed description of how leak compensation works with each circuit type.

WARNING: Delivered and monitored ventilation therapy may be affected by large leaks around the patient interface.

Circuit Type	Volume Ventilation (AC-Volume and SIMV-Volume)	Pressure Ventilation (Bi-Level, AC-Pressure, and SIMV-Pressure)	Volume Targeted Ventilation (Vol. Targeted-PS, Vol. Targeted-PC, and Vol Targeted-SIMV)
Passive	Yes	Yes	Yes
Valveless	Yes	Yes	Yes
Mouthpiece	(n/a)	(n/a)	(n/a)

Leak Compensation with a Passive or Valveless Ventec One-Circuit

Because passive circuits (and valveless circuits connected to a vented mask) have a fixed and constant leak, VOCSN runs its leak compensation continuously in the background to calculate and compensate for leaks. VOCSN devices with the Leak+ feature can compensate for large leaks up to 175 L/min at 20 cmH₂O. When VOCSN detects a leak in a passive or valveless circuit configuration, it compensates by adjusting the following aspects of Ventilation therapy and the monitors:

- PEEP, to maintain the set pressure for any leak up to 50 L/min @ 10 cmH₂O.
- Volume breaths, to ensure the delivered volume is accurate.
- Pressure breaths, to ensure the pressure at the patient end of the circuit is accurate for any leak up to 50 L/min @ 10 cmH₂O.
- Flow Triggering, to maintain consistent patient effort without autocyling.
- The Estimated V_{te} and Minute Volume monitor, as well as the flow and volume waveforms, to display the actual therapy delivered to the patient.

Leak Compensation with a Mouthpiece Circuit

Mouthpiece patient circuits are open to ambient air between breaths, and so have a constant large leak. Patients use their mouth to create a seal around the circuit while taking a breath. Because it is unnecessary, leak compensation is not active during Ventilation therapy with a mouthpiece patient circuit.

Nebulization

V*Home can be used to compensate for the added flow to the patient circuit from an external nebulizer.

External Nebulizer Compensation

When External Neb. Comp is on, flow from V*Home is reduced by 5.9 L/min to compensate for flow from the external nebulizer. The V*Home monitors also recalculate to reflect the 5.9 L/min of additional flow.

Because the V*Home FiO₂ monitor measures gas delivered through the device, FiO₂ oxygen delivery during External Neb. Compensation may be higher or lower than monitored by V*Home, depending on the source driving a connected external nebulizer. If the external nebulizer is driven by air, the FiO₂ to the patient will be lower than the set and monitored FiO₂. If the external nebulizer is driven by oxygen, the FiO₂ to the patient will be higher than the set and monitored FiO₂. If a precise FiO₂ is required during External Neb. Compensation, Ventec Life Systems recommends using an ultrasonic nebulizer instead.

If the patient is oxygen dependent, Ventec Life Systems recommends use of patient oxygen monitoring (e.g., an SpO₂ monitor), especially during nebulization.

NOTE: To ensure proper device operation, all nebulizer parts connected to V*Home should comply with the relevant requirements of ISO 27427.

V*Home Measurements

Airway Pressure Measurements

A transducer inside V*Home takes pressure measurements to help assure the accuracy of delivered breath pressure, including PEEP. V*Home also contains a second, redundant transducer to ensure accurate, reliable measurements.

The pressure measurements taken by transducers inside V*Home are then combined with measurements taken while running the Pre-Use Test (to determine the resistance, compliance, and leak of the Ventec One-Circuit). Using these two measurements, V*Home calculates the airway pressure at the patient interface (mask, tracheal tube, or mouthpiece).

To ensure the set PEEP is maintained when using a passive or valveless circuit, V*Home calculates and delivers the flow required to reach and maintain the set PEEP.

In addition, Ventec Life Systems recommends the use of appropriate alarms to ensure the accuracy of delivered breath pressure. For example, the High Pressure and Low Inspiratory Pressure alarms, as well as the Low Minute Volume alarm can be set to ensure breaths are accurately delivered during pressure-control ventilation.

NOTE: If the High Pressure and Low Inspiratory Pressure alarms, and/or Low Minute Volume alarms are not set to detect problems with Ventilation therapy, ensure the rest of your alarm suite is configured appropriately to detect any problems with the delivered ventilation.

Flow Measurements

When using a passive or valveless Ventec One-Circuit or mouthpiece patient circuit, V*Home calculates flows using measurements from its internal transducers and the Pre-Use Test.

Volume Measurements

Exhaled volumes are calculated using measurements from transducers inside V*Home, and measurements from the Pre-Use Test.

FiO2 Measurements

V*Home includes an integrated FiO2 monitor, which takes measurements as gas travels to the Ventec One-Circuit connection port.

The Calculated FiO2 monitor calculates the estimated FiO2 delivered to the patient, based on V*Home settings and the patient's breathing patterns. The calculation will change as breathing patterns change, or when V*Home Ventilation settings are modified.

Alarm Detection Criteria

Alarm	Detection Criteria
Patient Circuit Disconnect	<p>When High Flow is Off and the Circuit Type control is set to Passive or Valveless:</p> <ul style="list-style-type: none"> • If Sensitivity is set to "0-75," the alarm activates when the measured leak persists at more than 15.4 L/min/(cmH2O^{0.59}) • If Sensitivity is set to "75-175," the alarm activates when the measured leak persists at more than 30 L/min/(cmH2O^{0.59}) <p>When High Flow is On, when patient breathing of 20 L/min is not detected for more than 20 seconds.</p>
System Fault (all conditions)	<p>If V*Home detects any of the conditions described in the <i>"System Fault Detection Criteria and Recommended Action"</i> on page 177, the System Fault alarm will activate. Depending on the System Fault condition, some therapies may be suspended or terminated.</p> <p>Use the Event Log to determine the System Fault number. Some System Fault conditions require providing the patient with backup therapy, while others may be resolved by following the recommended actions described below.</p>

System Fault Detection Criteria and Recommended Action

Alarm	Detection Criteria	VOCSN Action	Recommended Action
System Fault 9	When the Ventilation therapy fan does not turn.	No action.	Provide the patient with backup Ventilation (and other therapies if necessary). Restart V*Home. If the problem persists, contact Ventec Life Systems for service.
System Fault 10	When the redundant transducers in V*Home detect pressures that differ by >5 cmH ₂ O.	Ventilation and Oxygen will continue to operate using the higher measurement of the two.	Provide the patient with backup Ventilation (and other therapies if necessary). Restart V*Home. If the problem persists, contact Ventec Life Systems for service.
System Fault 11	When the patient circuit pressure is negative for more than 100 milliseconds during ventilation.	No action.	Provide the patient with backup Ventilation (and other therapies if necessary). Restart V*Home. If the problem persists, contact Ventec Life Systems for service.
System Fault 14	When all V*Home settings are reset to factory defaults because of a corruption of the stored settings.	Entry of the Clinician Access Passcode is required to reset this condition.	Immediately provide the patient with backup therapy. Enter the Clinician Access Passcode and then manually re-enter all patient settings.
System Fault 15	When the alarm process and/or alarm tones do not activate and are unrecoverable for >30 seconds.	No action.	Immediately provide the patient with backup therapy. Restart V*Home. If the problem persists, contact Ventec Life Systems for service.

Low-Pressure Oxygen Blending

When using the a low-pressure oxygen source to bleed oxygen into a passive or valveless Ventec One-Circuit, oxygen delivered to the patient may fluctuate based on the following settings and conditions:

- Oxygen flow rate
- Leaks in the Ventec One-Circuit
- Flow Trigger setting
- I:E Ratio setting
- Tidal Volume setting
- Breath Rate
- Pressure Control setting
- Pressure Support setting

The following graphs illustrate the expected FiO₂ based on the patient minute volume when using the FiO₂ control to bleed a low-pressure external oxygen source through VOCSN and into an active Ventec One-Circuit.

NOTE: Increasing the Flow Trigger control setting requires additional oxygen (in L/min) to achieve the target FiO₂. In addition, any leaks in the Ventec One-Circuit will require a higher flow of oxygen input to achieve the target FiO₂.

The following four graphs display the expected FiO₂ with low-pressure O₂ blending at various minute volumes, with an input flow of 93% or 100% O₂, and a Flow Trigger setting of 1 to 3 or 9 L/min. Graphs are also provided for blending during High Flow therapy.

Input Flow 100% Oxygen, Flow Trigger Set to 1-3

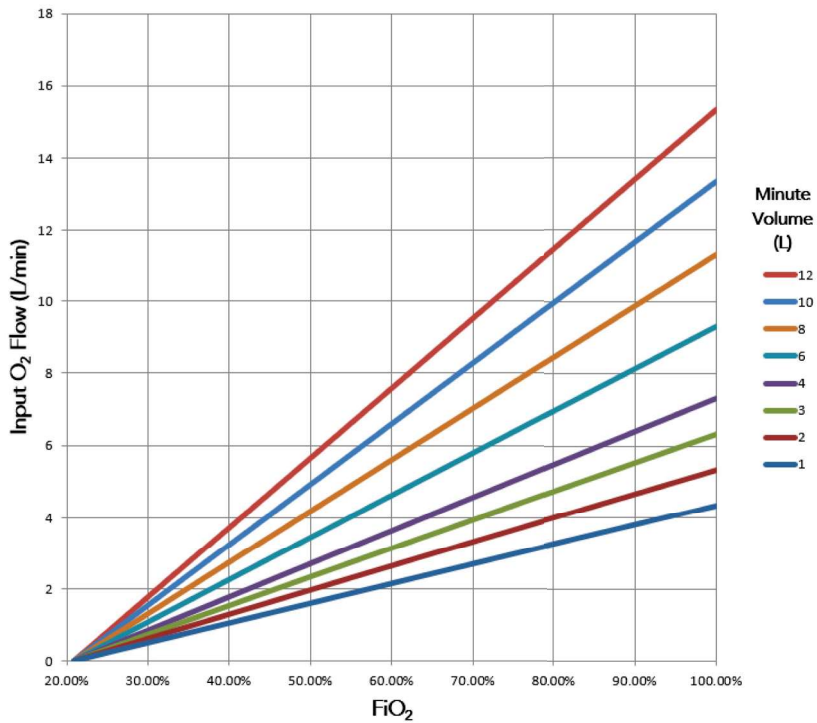

Input Flow 100% Oxygen, Flow Trigger Set to 9

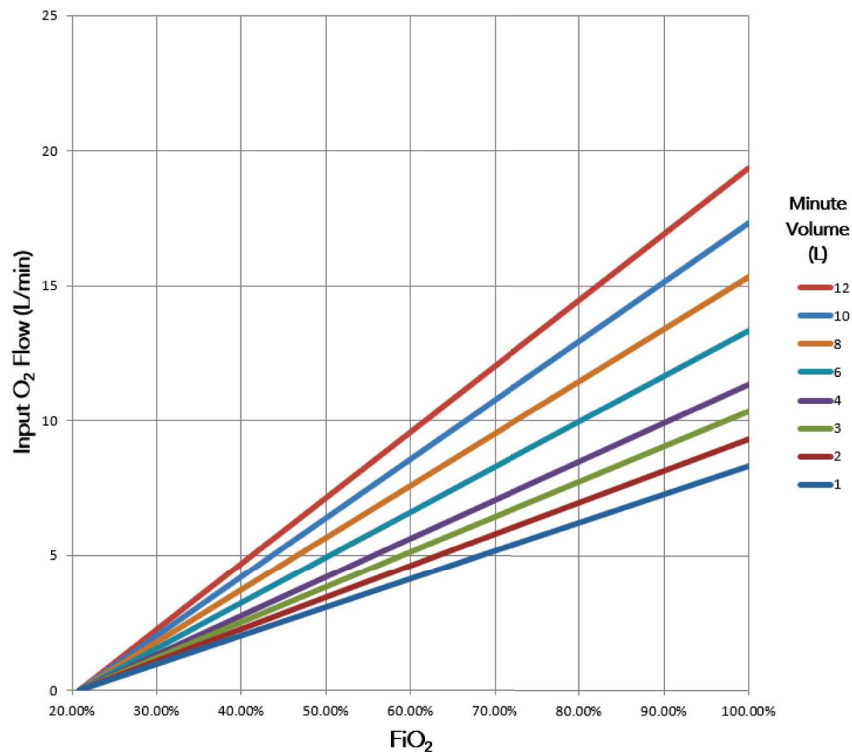

Input Flow 93% Oxygen, Flow Trigger Set to 1-3

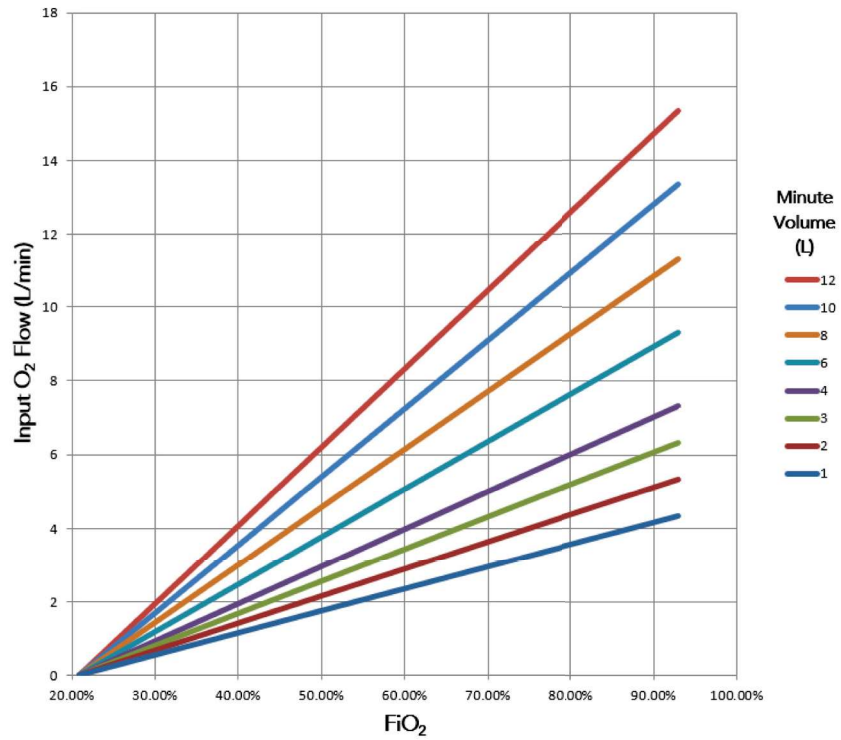

Input Flow 93% Oxygen, Flow Trigger Set to 9

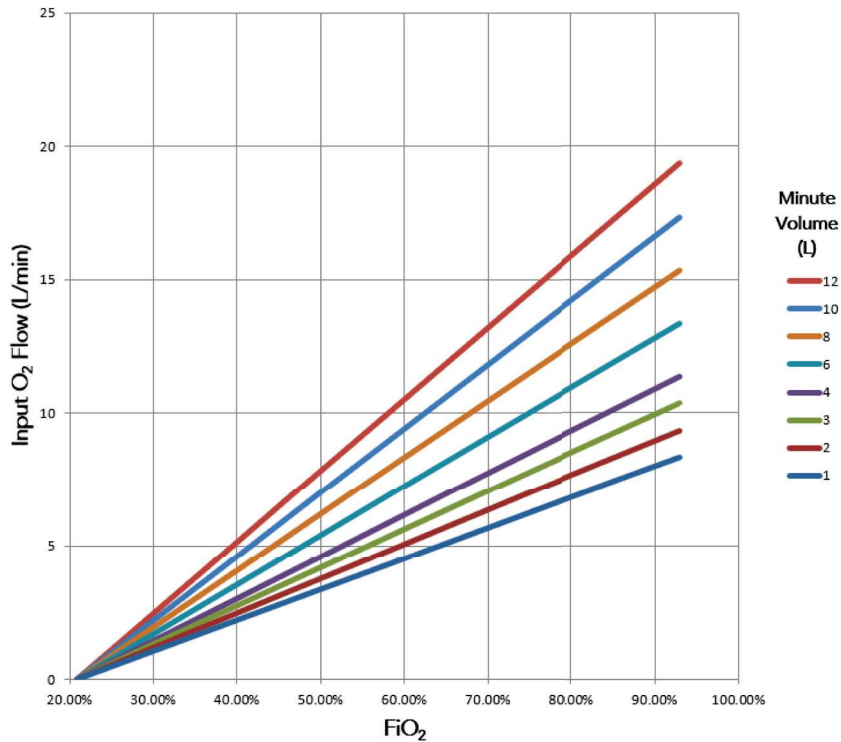

Input Flow 100% Oxygen, High Flow Therapy

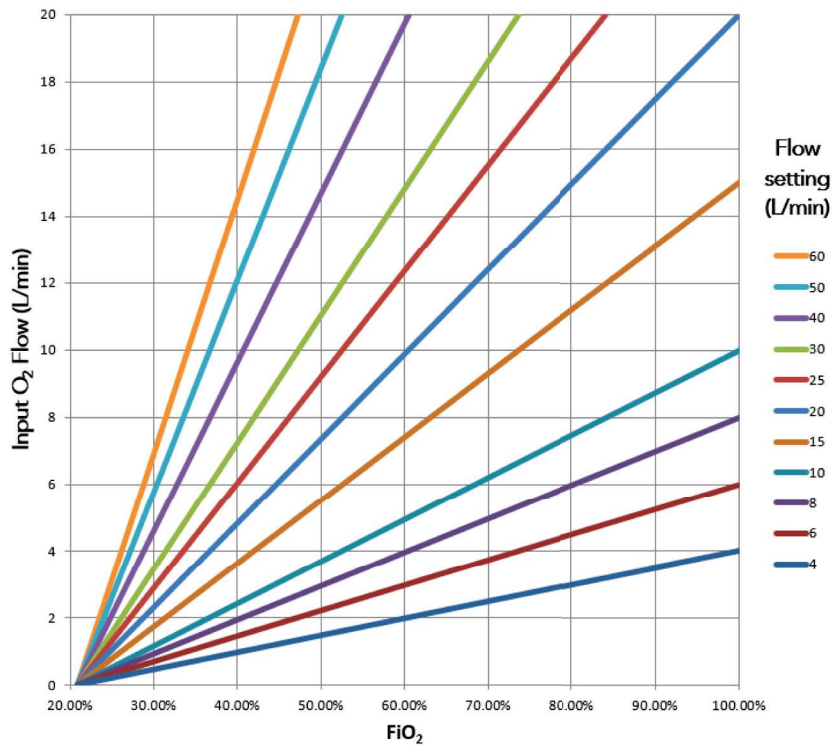

Input Flow 93% Oxygen, High Flow Therapy

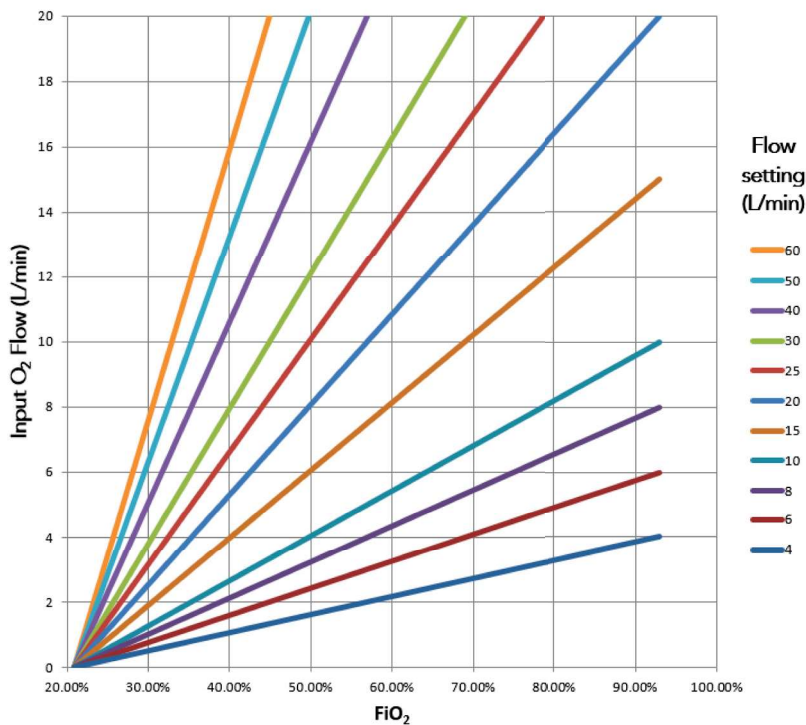

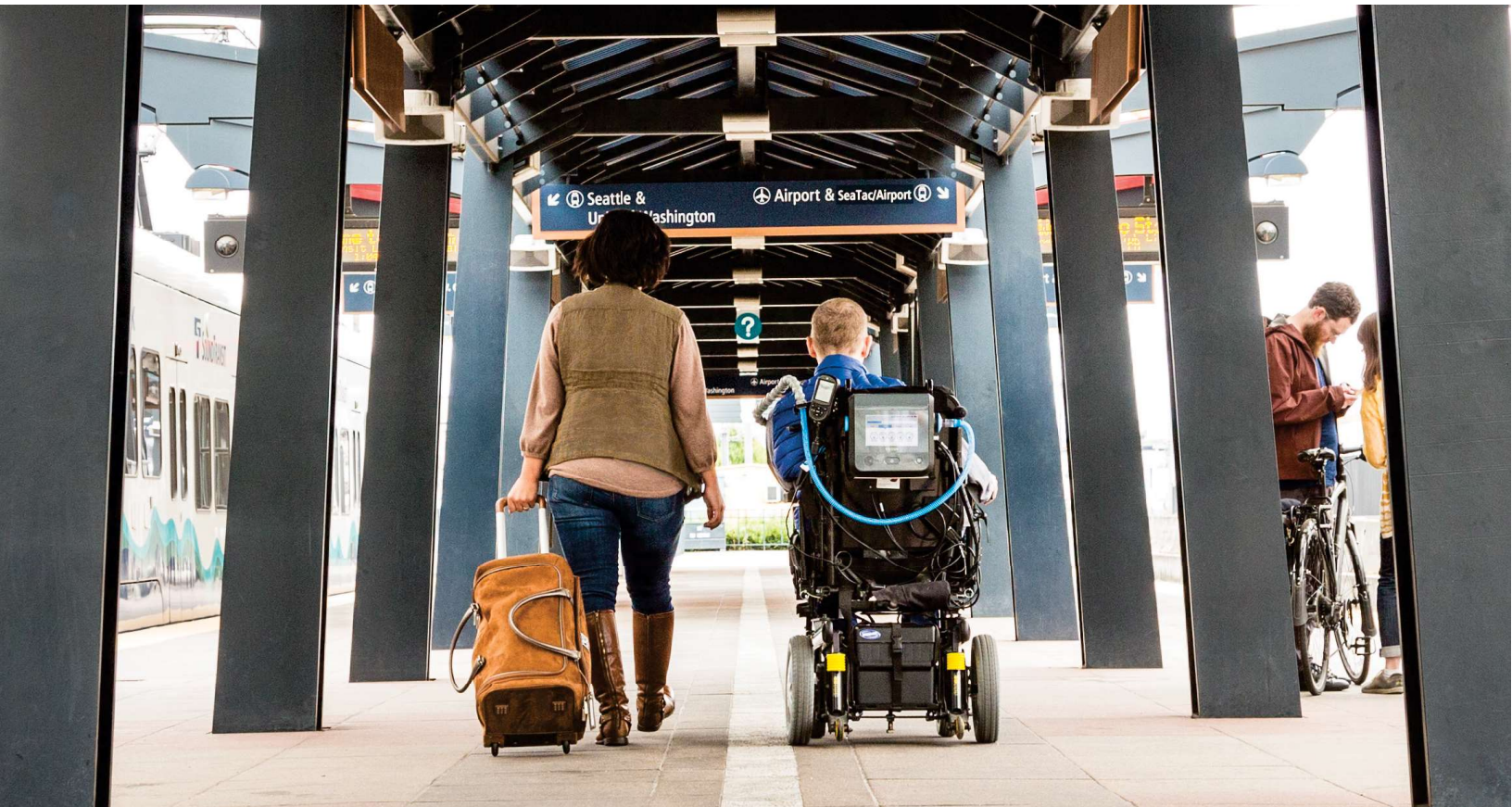

About Ventec Life Systems

Ventec Life Systems is defining integrated respiratory care to improve patient outcomes and reduce caregiver challenges in the hospital and home. Ventec's leading product, VOCSN, seamlessly integrates five separate devices including a ventilator, oxygen concentrator, cough assist, suction, and nebulizer into one unified respiratory system. The team's history of patient-centric design brings care changing innovations to life for patients, medical professionals, and caregivers.

For questions about V*Home:

VentecLife.com

ventec-info@reacthealth.com

1-844-698-6276

